

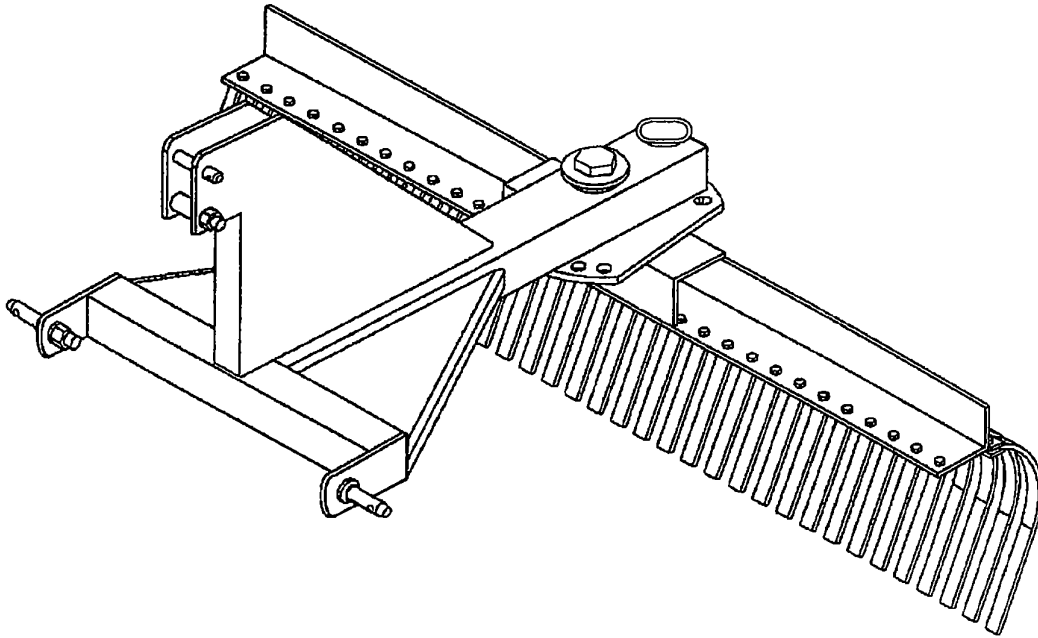

Taylor Pittsburgh Mfg., Inc.
P.O. Box 1866
Athens, TN 37371-1866
423-745-3110

FIELD GENERAL



LANDSCAPE RAKE

OWNERS MANUAL

Form 233-YR-G / 233-TYR-SC
March 2008

TO THE DEALER:

The Rake assembly and proper installation to the tractor is the responsibility of the TAYLOR PITTSBURGH dealer. Read manual instructions and safety rules. Make sure all items on the Pre-delivery and Delivery Check Lists are completed before releasing equipment to the owner.

TO THE OWNER:

Read this manual before operating your TAYLOR PITTSBURGH rear blade. The information presented will prepare you to do a better and safer job. Keep this manual handy for ready reference. Require all operators to read this manual carefully and become acquainted with all the adjustment and operating procedures before attempting to operate. Replacement manuals can be obtained from your dealer or by calling 1-423-745-3110, in the USA and Canada only.

The rear blade you have purchased has been carefully engineered and manufactured to provide dependable and satisfactory use. Like all mechanical products, it will require cleaning and upkeep. Lubricate the unit as specified. Observe all safety information in this manual and safety decals on the rear blade and tractor.

For service, your authorized TAYLOR PITTSBURGH dealer has trained mechanics, genuine TAYLOR PITTSBURGH service parts, and the necessary tools and equipment to handle all your needs.

Provide this information to your dealer to obtain correct repair parts.

LIMITED WARRANTY

TAYLOR PITTSBURGH MFG., INC., the manufacturer, warrants only to the Original Purchaser that this equipment, under normal use and service, will be free from defects in material and workmanship for one (1) year from date of purchase providing this equipment is purchased for individual and not for commercial use. Warranty for commercial usage is 90 days. This warranty does not apply to any equipment which has been damaged or which has been subjected to abuse, misuse, negligence, abnormal wear and tear, alterations, tampering, or failure to follow operating instructions. This warranty does not cover any product or parts not manufactured by Taylor Pittsburgh Manufacturing, Inc..

Under this warranty, the manufacturer will repair or replace any part which the manufacturer determines has failed during the period of the warranty due to defects in material or workmanship. After approval by the manufacturer, the equipment or defective part must be returned to Taylor Pittsburgh Mfg., Inc., Athens, Tennessee 37371.

PURCHASER'S EXCLUSIVE REMEDY FOR BREACH OF WARRANTY, OTHER DEFECT, OR CONDUCT GIVING RISE TO LIABILITY SHALL BE THE REPAIR OR REPLACEMENT OF THE PRODUCT SOLD, AND THE MANUFACTURER UNDER NO CIRCUMSTANCES SHALL BE LIABLE FOR ECONOMIC LOSS OR INCIDENTAL OR CONSEQUENTIAL DAMAGES. THE MANUFACTURER DISCLAIMS ALL IMPLIED WARRANTIES, INCLUDING THE WARRANTY OF MERCHANTABILITY AND FITNESS FOR PURPOSE.

Taylor Pittsburgh Mfg., Inc. reserves the right to make improvements and changes in specifications without notice or obligation to modify previously sold units.

This manual describes the proper assembly procedures for your rear blade and furnishes operating and maintenance recommendations to help you obtain long and satisfactory service.

SAFETY RULES



ATTENTION! BECOME ALERT! YOUR SAFETY IS INVOLVED!



SAFETY ALERT SYMBOL

FIG. 1: This is the safety alert symbol. It means **ATTENTION: BECOME ALERT! YOUR SAFETY IS INVOLVED!** Look for it, both in this manual and on safety decals on the equipment. It will direct your attention to information that involves your safety and the safety of others.



Figure 1

SIGNAL WORDS

FIG. 2: The words **DANGER**, **WARNING** or **CAUTION** are used with the safety alert symbol. Learn to recognize these safety alerts, and follow the recommended precautions and safe practices.



DANGER: The safety alert symbol, with the word **DANGER**, indicates an imminently hazardous situation that, if not avoided, will cause **DEATH OR VERY SERIOUS INJURY**.



WARNING: The safety alert symbol, with the word **WARNING**, indicates a potentially hazardous situation that, if not avoided, could cause **DEATH OR SERIOUS INJURY**.



CAUTION: The safety alert symbol, with the word **CAUTION**, indicates a potentially hazardous situation that, if not avoided, may cause a **MINOR INJURY**.



Figure 2

Replace any **DANGER**, **WARNING**, **CAUTION** or instructional decal that is not readable or is missing. The location and part number of these decals is identified later in the section of the manual.

IMPORTANT: The word **IMPORTANT** is used to identify special instructions or procedures which, if not strictly observed could result in damage to, or destruction of the machine, process or its surroundings.

GENERAL INFORMATION

INTRODUCTION

READ THIS MANUAL carefully to learn how to properly operate and service your landscape rake. Failure to do so could result in personal injury or equipment damage.

Throughout this manual, references are made to right and left direction. **RIGHT - HAND AND LEFT - HAND** sides are determined by standing behind the landscape rake facing the direction the landscape rake will travel when going forward.

The purpose of this manual is to assist you in operating and maintaining your Series 2 3 3 Landscape Rake. Read it carefully. It furnishes information and instructions that will help you achieve years of dependable performance. These instructions have been compiled from extensive field experience and engineering data. Some information may be general in nature due to unknown and varying operating conditions.

However, through experience and these instructions, you should be able to develop procedures suitable to your particular situation. Maintain your landscape rake with original repair parts to insure optimum performance.

The illustrations and data used in this manual were current at the time of printing, but due to possible production changes, your landscape rake may vary slightly in detail. We reserve the right to redesign and change the machines as may be necessary without notification.

BOLT TORQUE CHART

GRADE 2

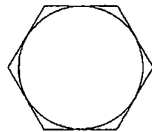

GRADE 5

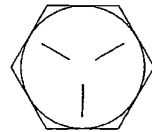

GRADE 8

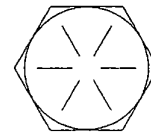

TORQUE IN FOOT POUNDS (NEWTON METERS)

BOLT SIZE	3/8	1/2	5/8	3/4	7/8	1	
HEX HEAD	9/16	3/4	15/16	1-1/8	1-5/16	1-1/2	
GRADE	2	18 (24.4)	45 (61.0)	89 (120.7)	160 (216.9)	252 (341.6)	320 (433.9)
	5	30 (40.6)	68 (92.2)	140 (189.8)	240 (325.4)	360 (488.1)	544 (737.5)
	8	40 (54.2)	100 (135.6)	196 (265.7)	340 (460.9)	528 (715.1)	792 (1073.8)

TABLE OF CONTENTS

WARRANTY	1
SAFETY SYMBOLS & SIGNAL WORDS	2
GENERAL INFORMATION.....	3
BOLT TORQUE CHART	3
SPECIFICATIONS	4
SAFETY RULES	5 - 6
SAFETY DECALS & LOCATIONS	7
OPERATION	8
ASSEMBLY	8
BEFORE OPERATION	8
ATTACHING	9
OPERATION	9
TRANSPORTING	9
DETACHING	9
MAINTENANCE	10
STORAGE	10
RAKE COMPONENTS	11 - 12
GAUGE WHEEL COMPONENTS	13

MODEL	233-TY-G				233-TYR-SC
SPECIFICATIONS	60"	72"	84"	96"	60"
Rake Width - in. (mm)	60 (1524)	72 (1828.8)	84 (2133.6)	96 (2438.4)	60 (1524)
Rake Height - in. (mm)	15 (381)	15 (381)	15 (381)	15 (381)	10 (254.4)
Approx. Weight - lbs. (kg)	200 (90.6)	240 (108.7)	280 (126.9)	321 (145.5)	189 (85.6)
Tractor HP	12 - 50	12 - 50	15 - 50	15 - 50	Up to 25
3 Point Hitch (Clevis)	Cat I	Cat I	Cat I	Cat I	Cat I
Rake Positions	5 Forward 5 Reverse	5 Forward 5 Reverse	5 Forward 5 Reverse	5 Forward 5 Reverse	5 Forward 5 Reverse
Tines (Spring Steel)	5/16" x 1" (7.93 x 25.4)	5/16" x 1" (7.93 x 25.4)	5/16" x 1" (7.93 x 25.4)	5/16" x 1" (7.93 x 25.4)	5/16" x 1" (7.93 x 25.4)
Number of Tines	30	36	42	48	30

SAFETY RULES



ATTENTION! BECOME ALERT! YOUR SAFETY IS INVOLVED!



Your personal safety is a primary concern in the design and manufacture of our products. Unfortunately, our efforts to provide such equipment can be wiped out by a single careless act of an operator.

In addition to the design and configuration of equipment, hazard control and accident prevention are dependent upon the awareness, concern, prudence and proper training of personnel involved in the operation, transport, maintenance and storage of equipment.

It has been said “**The best safety device is an informed, careful operator.**” We ask you to be that kind of an operator.

The design of this equipment depends on it being operated within the limitations as explained in this manual.

TRAINING

- **Safety instructions are important! Read this manual and the tractor manual; follow all safety rules and safety decal information. (Replacement manuals are available from your dealer). Failure to follow instructions or safety rules can result in serious injury or death.**
- **If you do not understand any part of this manual and need assistance, see your dealer.**
- **Know your controls and how to stop engine and attachment quickly in an emergency.**
- **The operator must be instructed in and be capable of the proper operation of the equipment, its attachments and all controls. Do not allow anyone to operate this equipment without proper instructions.**
- **Do not allow children or untrained persons to operate equipment.**

PREPARATION

- **Always wear close fitting clothing and personal protection equipment called for by the job conditions. These items may include a hard hat, safety glasses, goggles or face shield, hearing protection and safety boots. DO NOT wear loose clothing, jewelry or any other items that may be entangled in moving parts. Tie up long hair.**
- **Ensure landscape rake is properly mounted, adjusted and in good operating condition.**
- **Tighten all bolts and nuts and check that all cotter pins are installed securely to ensure equipment is properly assembled before operating.**
- **Tractor must be equipped with ROPS FRAME or ROPS CAB and seat belt. Keep seat belt securely fastened. Falling off tractor can result in death from being run over or crushed. Keep foldable ROPS systems in “locked up” position at all times.**
- **A minimum 20% of the combined tractor and landscape rake weight must be on the tractor front wheels with landscape rake in transport position. Without this weight, tractor could tip over causing personal injury or death. See your tractor operators manual for information regarding adding weights.**
- **Remove accumulated debris from this equipment, tractor and engine to avoid fire hazard.**
- **Ensure all safety decals are installed. Replace if damaged. (See Safety Decals section for location.)**

OPERATIONAL SAFETY

- **Keep bystanders away from equipment while it is in operation.**
- **Operate only in daylight or good artificial light.**
- **Always comply with all state and local lighting and marking requirements.**
- **No riders on equipment.**
- **Always sit in tractor seat with seat belt fastened when operating controls or starting engine. Place transmission in park or neutral, engage brake and ensure all other controls are disengaged before starting tractor engine.**

(Safety Rules continued on next page)



SAFETY RULES



ATTENTION! BECOME ALERT! YOUR SAFETY IS INVOLVED!

(Safety Rules continued from previous page)

- Look down and to the rear and make sure area is clear before operating in reverse.
 - Do not operate on steep slopes.
 - Do not stop, start or change directions suddenly on slopes.
 - Use extreme care and reduce ground speed on slopes and rough terrain.
 - Watch for hidden hazards on the terrain during operation.
 - Stop tractor and rear Rake immediately upon striking an obstruction. Turn off engine, remove key, inspect and repair any damage before resuming operation.
 - When performing any service or maintenance, disengage power to implement. Lower all raised components to the ground. Operate valve levers to release any hydraulic pressure. Stop engine, set parking brake and remove key before dismounting tractor.
 - Keep all persons away from operator control area while performing adjustments, service or maintenance.
- Do not drive the tractor and landscape rake over 20 MPH (30 KPH) on the best surface conditions. Reduce speed when going up or down hills and when approaching ditches or corners.
 - Always comply with all state and local lighting and marking requirements.
 - Check condition of hitch pins and bolts before transporting.
 - Keep your landscape rake in proper working condition. Unauthorized modifications to the landscape rake may impair the function and affect landscape rake life. Do not add excessive weight to the landscape rake. Additional weight could cause frame to fail resulting in loss of control of landscape rake/tractor during transport.
 - Raise landscape rake to highest position for transport.
 - Watch low hanging Overhead Power Lines during transport. Avoid contact as this can cause serious injury or death.

MAINTENANCE SAFETY

- Before working underneath, raise landscape rake to highest position and block securely. Blocking up prevents landscape rake dropping from hydraulic leak down, hydraulic system failures, or mechanical failure on the tractor.
- Keep all persons away from operator control area while performing adjustments, service or maintenance.
- Your dealer can supply genuine replacement parts. Substitute parts may not meet original equipment specifications.
- Do not climb or walk on landscape rake frame.

TRANSPORTING SAFETY

- Use a Slow - Moving - Vehicle (SMV) emblem and proper lighting on the tractor when transporting the rear blade.

STORAGE

- Store on a level surface sheltered from the weather.
- Lower landscape rake to the ground and block to prevent rolling.
- Clean all debris from landscape rake.
- Coat soil engaging surfaces with a rust inhibitor after cleaning.
- Keep playing children and bystanders away from storage area.



SAFETY DECALS



ATTENTION! BECOME ALERT! YOUR SAFETY IS INVOLVED!
Replace Immediately If Damaged!

DECAL LOCATIONS

The following safety decals are located on your implement. Read them and follow their instructions. Keep all decals in place and legible. Replace worn or missing decals. Replacement safety decals are available through your dealer. Order by number listed.

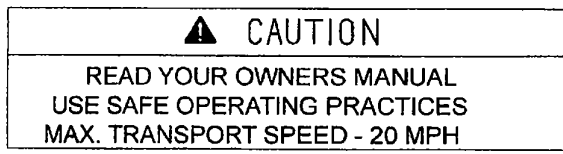

009537 - Front Cross Member of Main Frame

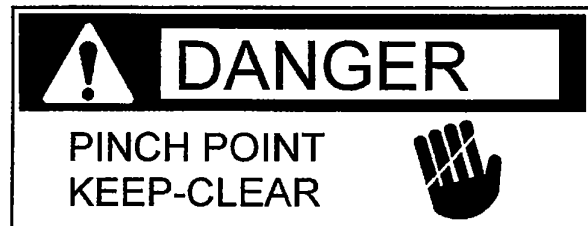

029772 - NEAR PIVOT BOLT ON TOP OF MAIN FRAME

OPERATION

Your personal safety is a primary concern in the design and manufacture of our products. Unfortunately, our efforts to provide such equipment can be wiped out by a single careless act of an operator.

In addition to the design and configuration of equipment, hazard control and accident prevention are dependent upon the awareness, concern, prudence and proper training of personnel involved in the operation, transport, maintenance and storage of equipment.

It has been said “**The best safety device is an informed, careful operator.**” We ask you to be that kind of an operator.

The operator must be properly trained. Operators should be familiar with the rear landscape rake and tractor and all safety practices before starting operation. Read the safety information on pages 1, & 5 through 6.

This landscape is designed for normal landscape usage.

Recommended landscaping speed for most conditions is from two to five mph.

Maintain your implement with original repair parts to insure optimum performance.

MODIFICATIONS

It is the policy of the manufacturer to improve its products whenever possible and practical. We reserve the right to make changes, improvements, and modifications at any time without incurring the obligation to make such changes, improvements, and modifications on any implement sold previously.

ASSEMBLY

General

Your Series 233 Landscape Rake is shipped fully assembled. No additional assembly is required.

If gauge wheels are to be installed, follow these steps:

- 1) Block up hitch of rake so the rake is level.
- 2) Attach the wheel arms to rake frame with HHCS 3/8 X 1-1/2
- 3) Adjust height spacer until desired tine depth is obtained.

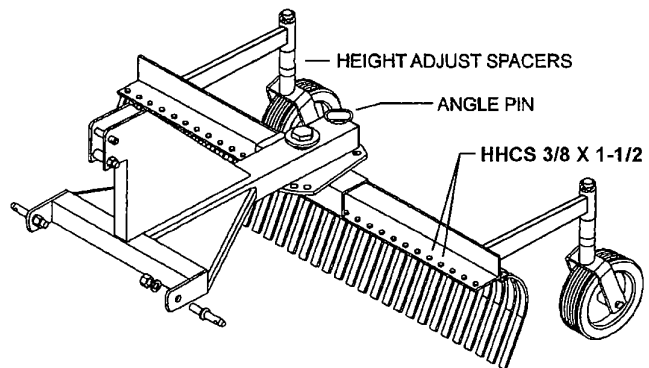

Assemble parts for each step loosely to insure fit. Use flatwashers with slotted holes. Always use lockwashers unless a lock nut is called for. Tighten hardware after parts are installed according to the torque chart on Page 3. Unless otherwise stated, all hardware is Grade 5. The following assembly steps are given to minimize the need for adjustment after assembly. Remember that **LEFT** and **RIGHT** are determined by standing at the rear of the implement and facing it.

BEFORE OPERATION

- 1) Tighten all loose hardware using the torque chart. Replace any missing hardware. On new machines, all hardware must be rechecked after first few hours of operation.
- 2) Replace any bent or broken parts.
- 3) Refer to your Tractor's Owner's Manual for recommended adjustments and weight distribution.
- 4) Check rake for signs of wear or damage. Replace if necessary. **SEE MAINTENANCE.**
- 5) Read the **SAFETY** section of this manual to be sure of all precautions.

ATTACHING

WARNING

Be sure bystanders are clear. Do not stand between implement and tractor. Shut off tractor and engage parking brake prior to dismounting.

- 1) Back tractor to align three--point lower arms with frame pins.
- 2) Attach left lower link arm to frame first and secure with click pin.
- 3) Using tractor right leveling crank, align right lower link arm with link pin. Attach arm to link pin and secure with click pin.
- 4) Attach top link between the frame and the tractor with a pin and secure with click pins.

OPERATION

Adjustments

Depth Control:

The desired operating depth is selected by using the tractor's position control lever or gauge wheels. When using position control, the rake will operate at the same depth, below the line of travel of the tires, until the setting is changed.

Position Adjustment

The landscape rake may be operated in any of several positions. It can be operated in the "forward" position for pulling, or in the "reverse" position for pushing.

The rake has an angle adjustment of 0°, 15°, 30°, and 45° to the left or right in the **forward direction**. In the reverse position, the rake can be adjusted to 0°, 15°, or 30°.

To make an angle adjustment or to reverse the rake. Remove hairpin and pin and rotate rake frame to desired angle. Replace pin and hairpin.

TRANSPORTING

- 1) Use a Slow - Moving - Vehicle (SMV) emblem and proper lighting on the tractor when transporting the rear blade.

- 2) Always comply with all state and local lighting and marking requirements.

- 3) Do not road the landscape rake over 20 MPH (30 KPH) on the best surface conditions. Reduce speed when going up or down hills and when approaching ditches or corners.

- 4) Check condition of hitch pins and bolts before transporting.

- 5) Raise landscape rake to highest position for transport.

- 6) Travel at a speed safe for terrain and other conditions.

- 7) Keep your landscape rake in proper working condition. Unauthorized modifications to the landscape rake may impair the function, affect landscape rake life, and put you at risk. Do not add excessive weight to landscape rake. Additional weight could cause frame to fail resulting in loss of control of landscape rake/tractor during transport.

- 8) Use caution and be aware of oncoming traffic and roadside obstructions.

- 9) **DO NOT** transport on public roads at night.

DETACHING

- Lower landscape rake to the ground.

- Detach the tractor top link from the landscape rake..

- Lower the blade frame unto supports and shut off tractor engine. Be sure landscape rake is stable on supports.

- Detach tractor right hand lower link arm then left hand lower link arm from landscape rake.

MAINTENANCE

General

Your landscape rake is designed for minimum maintenance. By taking a few minutes prior to beginning operations and performing the following maintenance check, you will insure improved performance and longer life of your landscape rake.

Check to see that all teeth are in place and not broken. Replace any missing or broken teeth to get maximum performance.

STORAGE

- 1) Store on a level surface sheltered from the weather.
- 2) Lower equipment to the ground and block to prevent rolling.
- 3) Clean all debris from implement.
- 4) Coat soil engaging surfaces with a rust inhibitor after cleaning.
- 5) Keep playing children and bystanders away from storage area.

SUB-COMPACT RAKE

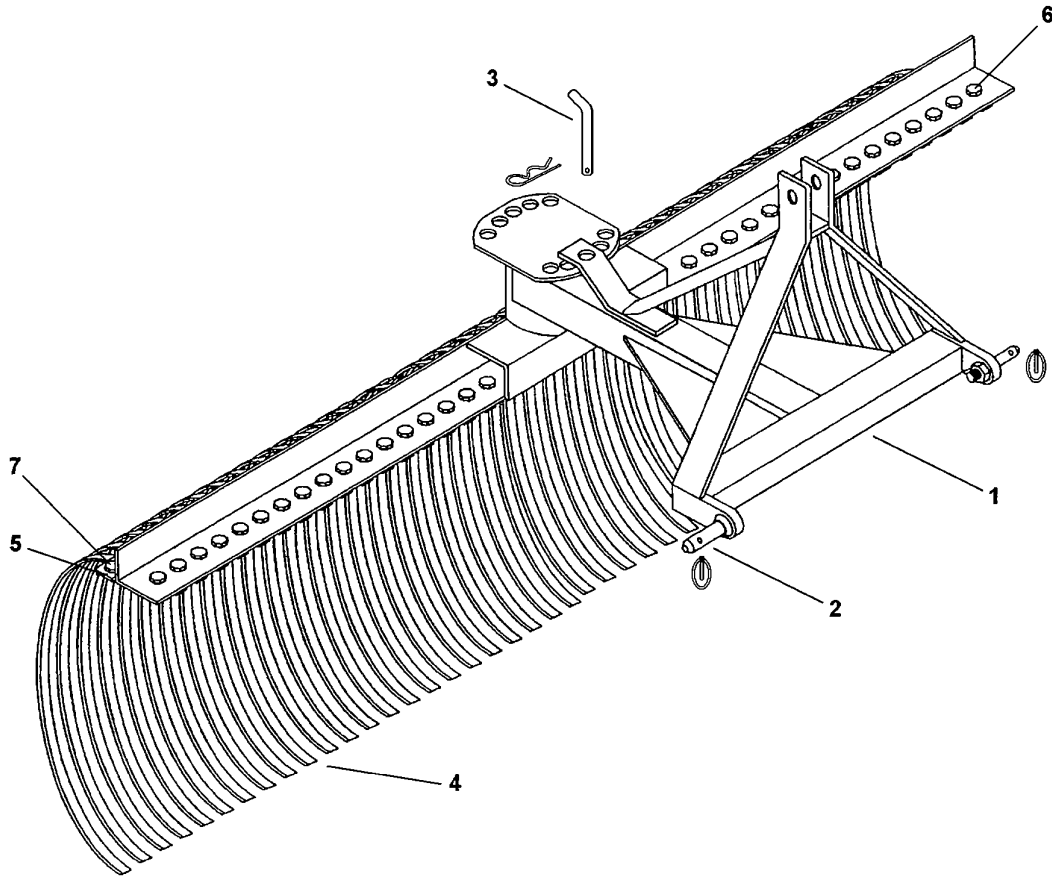

Series 233-TYR-SC

Item	Part #	Description	Qty
1	233-TYR-60-SC	Complete Rake	
2	203266	Cat.I LINK PIN	2
	303113	CLICK PIN 3/8"	2
3	813194	PIN / LOCK	1
	304244	HAIRPIN COTTER	1
4	503006	TINES (Package of 5)	---
5	350063	STRAP 1/4 X 1-1/2 X 60	2
6	303612	HH BOLT 3/8" X 1"	---
	303953	LOCKWASHER 3/8"	---
	304005	HEX NUT 3/8"-NC	---
7	303614	HH BOLT 3/8" X 1-1/2"	---
	304018	LOCKNUT 3/8"	---

G-STYLE RAKE COMPONENTS

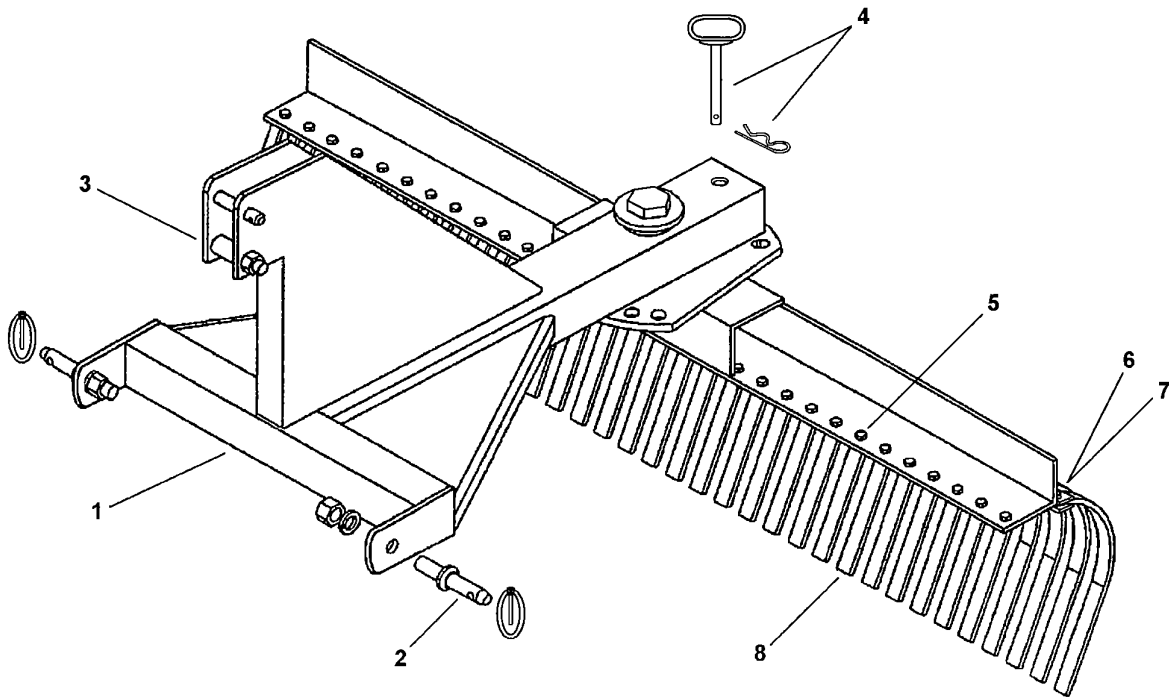

Series 233-YR-G

Item	Part #	Description	Qty
1	233-YR-G-60	Complete Rake	
	233-YR-G-72	Complete Rake	
	233-YR-G-84	Complete Rake	
	233-YR-G-96	Complete Rake	
2	203266	Cat.I LINK PIN	2
	303113	CLICK PIN 3/8"	2
3	303705	HHCS 3/4" X 4"	1
	304022	LOCKNUT 3/4"-NC	1
	952115	SLEEVE	1
4	813194	PIN / LOCK	1
	304244	HAIRPIN COTTER	1
5	303612	HH BOLT 3/8" X 1"	---
	303953	LOCKWASHER 3/8"	---
	304005	HEX NUT 3/8"-NC	---
6	303614	HH BOLT 3/8" X 1-1/2"	---
	304018	LOCKNUT 3/8"	---
7	350063	STRAP for 60" Rake	2
	350064	STRAP for 72" Rake	2
	350065	STRAP for 84" Rake	2
	350066	STRAP for 96" Rake	2
8	902028	TINE	---

GAUGE WHEEL COMPONENTS

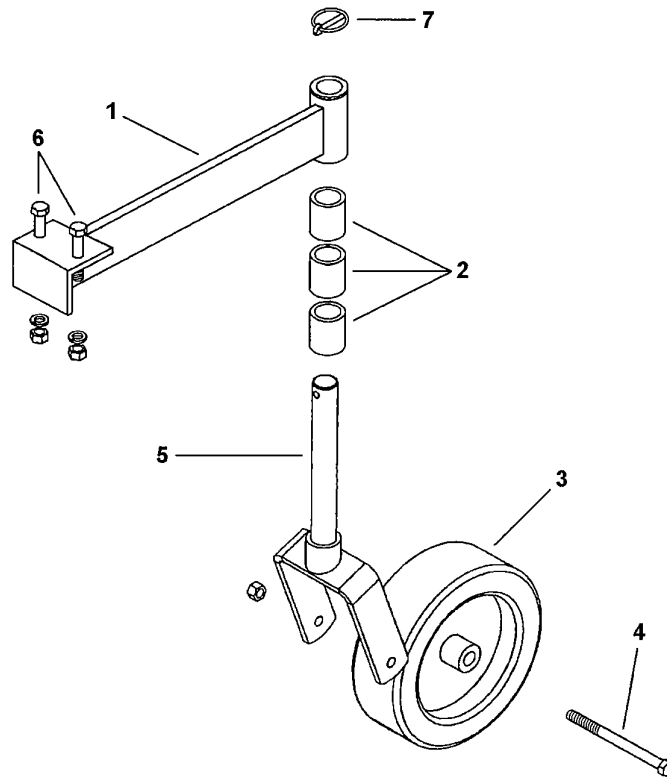

Used on Series 233-YR-G Style Rake ONLY!

Item	Part #	Description	Qty
1	403006	WHEEL ARM	2
2	953279	HEIGHT ADJ. SPACER	6
3	502020	TIRE & WHEEL	2
4	303707	HHCS 3/4" X 5-1/2"	2
	304022	LOCKNUT 3/4"	2
5	953281	WHEEL FORK	2
6	303614	HHCS 3/8" X 1-1/2"	4
	303953	LOCKWASHER 3/8"	4
	304005	HEX NUT 3/8"-NC	4
7	505576	CLICK PIN 1/4"	2

506005 COMPLETE GAUGE WHEEL KIT

