

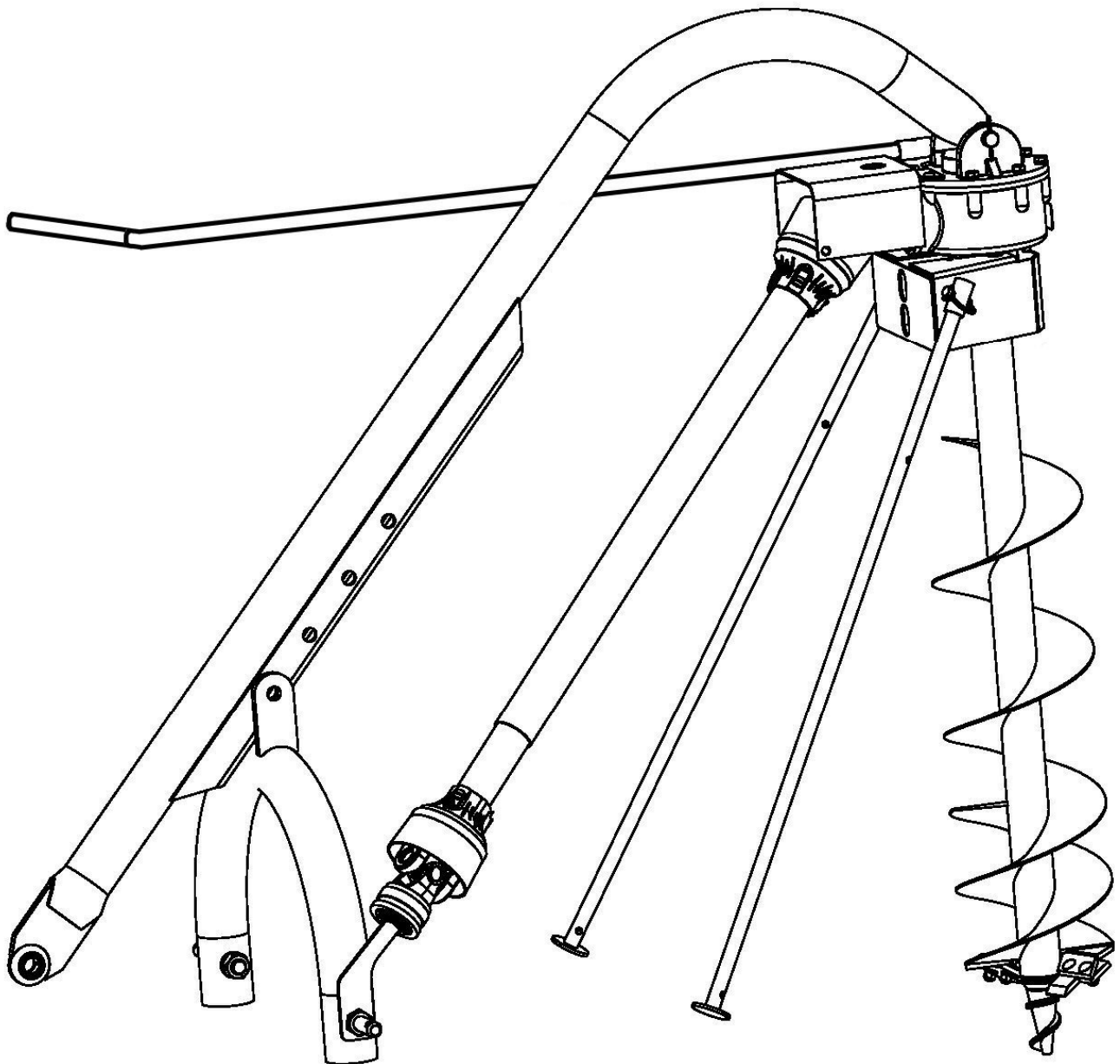

TAYLOR PITTSBURGH MFG., INC.
PO BOX 1200
WINFIELD, ALABAMA 35594
205-487-3202

233-PHD-YX



MAY 2024

TO THE PURCHASER

This manual contains valuable information about your new Taylor Pittsburgh Post Hole Digger. It has been carefully prepared to give you helpful suggestions for operating, adjusting, servicing and ordering repair parts.

Keep this manual in a convenient place for quick and easy reference. Study it carefully. You have purchased a dependable and sturdy post hole digger, but only by proper care and operation can you expect to receive the service and long life designed and built into the product.

Sometime in the future your post hole digger may need new parts to replace. If so, go to your dealer and provide them with the model and part number.

Customer Information

Name _____

Purchased From _____

Date Purchased _____

Model No. _____

Serial No. _____

It is the purchaser and/or operator's responsibility to....

- I Read and understand the information contained in this manual.**
- I Operate, lubricate, assemble and maintain the equipment in accordance with all instructions and safety procedures in this manual.**
- I Inspect the equipment and replace or repair any parts that are damaged or worn which under continued operation would cause damage, wear to other parts, or cause a safety hazard.**
- I Return the equipment or parts to the authorized Taylor Pittsburgh dealer, from where it was purchased, for service or replacement of defective parts that are covered by warranty. (The Taylor Pittsburgh Factory or an Authorized Taylor Pittsburgh Dealer may inspect equipment or parts before warranty claims are honored.)**

CONTENTS

ITEM	PAGE
Safety	6
Safety Training	8
Operational Safety.....	10
Transportation & Storage Safety	12
Safety Decals	13-17
Safety Signs Locations	18
Assembly & Attach To Tractor.....	19
Attach Gearbox To Boom, PTO Install & Sizing	20
Auger Attach To Gearbox	22
Operating Instructions & Lubrication.....	23
Lodged Auger	24
Shear Bolt Replacement, Transport & Storage.....	25
Parking Stand Install & Replace Cutting Edge	26
After Each Use	27
Replacement Parts	28
Bolt Torque Chart.....	30
Bolt Size Chart.....	31
Warranty	32

SAFETY

READ AND FOLLOW THE INSTRUCTIONS IN THIS MANUAL AND ESPECIALLY IN THE SAFETY SECTION. FAILURE TO DO SO CAN RESULT IN SERIOUS INJURY OR DEATH.

TAKE NOTE! THIS SAFETY ALERT SYMBOL FOUND THROUGHOUT THIS MANUAL IS USED TO CALL YOUR ATTENTION TO INSTRUCTIONS INVOLVING YOUR PERSONAL SAFETY AND THE SAFETY OF OTHERS.



THIS SYMBOL MEANS
ATTENTION!
BECOME ALERT!
YOUR SAFETY IS INVOLVED

SIGNAL WORDS:

The signal words **DANGER**, **WARNING** and **CAUTION** are used with the safety messages in this manual and with each safety sign. They are defined as follows:

DANGER: Indicates an immediate hazardous situation that, if not avoided, could result in serious injury or death. This signal word is to be limited to the most extreme situations typically for machine components that, for functional purposes, cannot be guarded.

WARNING: Indicates a potentially hazardous situation that, if not avoided, could result in serious injury or death, and includes hazards that are exposed when guards are removed. It may also be used to alert against unsafe practices.

CAUTION: Indicates a potentially hazardous situation that, if not avoided, may result in minor or moderate injury. It may also be used to alert against unsafe practice.

If you have any questions not answered in this manual or require additional copies or the manual is damaged, please contact your dealer or Taylor Pittsburgh, P.O. Box 1200 Winfield, AL 35594 (205) 487-3202 or www.taylorpittsburgh.com

EQUIPMENT SAFETY GUIDELINES



- I Safety of the operator and bystanders is one of the main concerns in designing and developing a post hole digger. However, every year accidents occur which could have been avoided by a few seconds of thought and a more careful approach to handling equipment. You, the operator, can avoid many accidents by observing the following precautions and insist those working with you, or for you, follow them.
- I In order to provide a better view, certain photographs or illustrations in this manual may show an assembly with a safety shield removed. However, equipment should never be operated in this condition. Keep all shields in place. If shield removal becomes necessary for repairs, replace the shield prior to use.
- I Replace any safety sign that is not readable or is missing. Copies of such safety signs are shown in this manual.
- I Never use alcoholic beverages or drugs that can hinder alertness or coordination while operating this equipment. Consult your doctor about operating this machine while taking prescription medications.
- I **Under no circumstances should children under the age of 18 be allowed to work with this equipment. Do not allow persons to operate or assemble this unit until they have read this manual and have developed a thorough understanding of the safety precautions and of how it works. Review the safety instructions with all users annually.**
- I This equipment is dangerous to children and persons unfamiliar with its operation. The operator should be a responsible, properly trained and physically able person familiar with farm machinery and trained in this equipment's operations. If the elderly are assisting with farm work, their physical limitations need to be recognized and accommodated.
- I Use a tractor equipped with a Roll Over Protective System and seat belts. (ROPS)
- I Never exceed the limits of a piece of machinery. If its ability to do a job, or to do so safely, is in question- **DON'T TRY IT.**
- I Do not modify the equipment in any way. Unauthorized modification could result in serious injury or death and may impair the function and life of the equipment.
- I In addition to the design and the confirmation of this implement, including safety signs and safety equipment, hazard control and accident prevention are dependent upon the awareness, concern, prudence, and proper training of personnel involved in the operation, transport, maintenance, and storage of the machine. Refer also to safety messages and operation instruction in each of the appropriate sections of the tractor and post hole digger manuals. Pay close attention to the safety signs affixed to the tractor and the post hole digger.

SAFETY TRAINING



- I Safety is a primary concern in the design and manufacture of our product. Unfortunately, our efforts to provide safe equipment can be wiped out by a single careless act of an operator or bystander.
- I In addition to the design and configuration of equipment, hazard control and accident prevention are dependent upon the awareness, concern, prudence and proper training of personnel involved in the operation, transport, maintenance and storage of this equipment.
- I It has been said, “The best safety device is an informed, careful operator.” We ask you to be that kind of operator. It is the operator’s responsibility to read and understand all safety and operating instructions in the manual and to follow them. Accidents can be avoided.
- I Working with unfamiliar equipment can lead to careless injuries. Read this manual, and the manual for your tractor, before assembly or operating, to acquaint yourself with the machines. If this machine is used by any person other than you, or is loaned or rented, it is the post hole digger owner’s responsibility to make certain that owner's manual be available to the operator prior to operating and that the operator:
 - 1- Reads and understands the operator’s manuals.
 - 2- Is instructed in safe and proper use.
- I Know your controls and how to stop tractor, engine, and the post hole digger quickly in an emergency. Read this manual and the one provided with your tractor.
- I Train all new personnel and review instructions frequently with existing workers. Be certain only a properly trained and physically able person will operate the machinery. A person who has not read and understood all operating and safety instructions is not qualified to operate the machine. An untrained operator exposes himself and bystanders to possible serious injury or death. If the elderly are assisting with farm work, their physical limitations need to be recognized and accommodated.

PREPARATION



- I Never operate the tractor and post hole digger until you have read and completely understand this manual, the Tractor Operator's Manual, and each of the safety messages found on the safety signs on the tractor and digger.
- I Personal protection equipment including hardhat, safety glasses, safety shoes, and gloves are recommended during assembly, installation, operation, adjustment, maintenance, repairing, removal, or moving the implement. Do not allow long hair, loose fitting clothing, or jewelry to be around equipment.
- I **PROLONGED EXPOSURE TO LOUD NOISE MAY CAUSE PERMANENT HEARING LOSS!** Tractors with or without post hole diggers attached can often be noisy enough to cause permanent, partial hearing loss. We recommend that you wear hearing protection on a full-time basis if the noise in the operator's position exceeds 80 db. Noise over 80 db. on a long-term basis can cause severe hearing loss. Noise over 90 db. adjacent to the operator over a long-term basis may cause permanent, total hearing loss. **NOTE:** Hearing loss from loud noise (from tractors, chain saws, radios, and other such sources close to the ear) is cumulative over a lifetime without hope of natural recovery.
- I Operate the post hole digger only with a tractor equipped with an approved Roll-Over-Protective System (ROPS). Always wear your seat belt. Serious injury or even death could result from falling off the tractor — particularly during a turnover when the operator could be pinned under the ROPS or the tractor.
- I Operate only in daylight or good artificial light.
- I Ensure the post hole digger is properly mounted, adjusted and in good operating condition.
- I Ensure that all safety shielding and safety signs are properly installed and in good condition.

STARTING AND STOPPING SAFETY



- I Check the tractor master shield over the PTO stub shaft. Make sure it is in good condition and fastened securely to the tractor. Purchase a new shield if old shield is damaged or missing.
- I All tractors that are not equipped with a "live" power takeoff (PTO) need to be equipped with an over-running PTO clutch. These are available through most farm equipment stores. **NOTE:** The addition of an over-running PTO clutch may change the length of the PTO driveline required. Pay extra attention to the instructions on the PTO driveline Installation. Be sure that the driveline system guarding is adequate.
- I The post hole digger operating power is supplied from the tractor PTO. Refer to your tractor manual for PTO engagement and disengagement instructions. Know how to stop tractor and post hole digger quickly in case of an emergency.

OPERATIONAL SAFETY



This product is designed to dig holes in the soil when attached to the 3-point linkage system and PTO of a tractor. It is **not** intended for any other use! Using the product for anything other than digging holes could result in serious injury or death!

- I The use of this equipment is subject to certain hazards that cannot be protected against by the mechanical means or product design. All operators of this equipment must read and understand this entire manual, paying particular attention to safety and operating instructions, prior to using. If there is something in this manual you do not understand, ask your supervisor, or your dealer, to explain it to you.
- I Most accidents occur because of neglect or carelessness. Keep all helpers and bystanders at least several feet from an operating post hole digger. Only properly trained people should operate this machine.
- I When machine is operated in populated area **operation must be stopped when anyone comes within 25 feet.**
- I The majority of the accidents involve entanglement on the driveline and operators being knocked off the tractor by low hanging limbs. Accidents are most likely to occur with machines that are loaned or rented to someone who has not read the owner's manual and is not familiar with a post hole digger and or a tractor.
- I The post hole digger is designed for use only on tractors with **540-RPM** power take off.
- I Install and secure all guards and shields before starting or operating. The driveline guards and tractor shields should be used and maintained in good working condition. They should be inspected carefully, at least daily, for missing or broken cable, chain links, shields, or guards. (Worn items must be replaced at once to reduce possibility of injury)
- I Disengage power takeoff (PTO) and place transmission in neutral before attempting to start engine.
- I Many varied objects, such as wire, cable, rope, or chains, can become entangled in the operating parts of the digger. These items could then swing at great velocities. Such a situation is extremely hazardous. Inspect the area for such objects before digging. Remove any like objects from the site.
- I Never allow the auger to contact such items. Never assume an area is clear. **Always Check!**



- I Always stop the tractor, disengage PTO, set brake, shut off the tractor engine, remove the ignition key, lower implement to the ground and allow auger to come to a complete stop before dismounting tractor. Never leave equipment unattended with the tractor running.
- I Never place hands or feet close to post hole digger with tractor engine running or before you are sure all motion has stopped. Stay clear of all moving parts.
- I Do not reach or place any part of your body close to equipment until it is blocked securely.
- I Do not allow riders on the tractor at anytime. There is no safe place for any riders.
- I Do not operate unless all personnel, livestock, and pets are several feet away to prevent injury.
- I The rotating parts of this machine have been designed and tested for rugged use. However, they could fail upon impact with heavy, solid objects such as steel guardrails and concrete abutment. Such impact could cause the broken objects to be thrown outward. To reduce the possibility of property damage, serious injury, or even death, never allow the auger to contact such obstacles.
- I Stop the post hole digger and tractor immediately upon striking an obstruction. Turn engine off, remove key, inspect and repair any damage before resuming operation.
- I Stay alert for uneven terrain, rocks, and roots and other hidden hazards. Keep away from drop-offs and hazards that could cause roll over. Use extreme care and maintain minimum ground speed when transporting or operating on hillsides, over rough ground and when operating close to ditches or fences. Be careful and slow down when turning sharp corners and changing direction on slopes. Do not start or stop suddenly on slopes. Avoid operation on steep slopes. In extremely uneven terrain, rear wheels weights, front tractor weight, and/or tire ballast should be used to improve stability.
- I Always check tractor manual for proper use on slopes.
- I When using a unit, a minimum 20% of tractor and equipment weight must be on tractor front wheels. Without this weight, tractor could tip over, causing personal injury or death. The weight may be attained with a front- end loader, front wheel weights, ballast in the tires or front tractor weights. When attaining a minimum 20% of tractor and equipment weight on the front wheels, you must not exceed the ROPS weight certification. Weigh the tractor and equipment. **Do not guess or estimate!**
- I Before digging contact your local utility companies (electrical, telephone, gas, water, sewer and others) before digging so that they can mark the location of any underground services in the area. Be sure to ask just how close you can work to the marks they positioned. Avoid contact with any overhead utility lines or electrically charged conductors.

OPERATIONAL SAFETY *continued...*



- I Do not operate the digger when the auger is more than 12” above the ground level or the driveline may bind causing injury to the operator and damage to the equipment.
- I Do not attempt to manually guide the auger point for location or to manually push down on the auger while it is in operation. Do not put anything or anyone on the auger for the purpose of adding weight to the unit. Objects and people can be thrown or become entangled in the unit.

TRANSPORT SAFETY



- I Comply with state and local laws governing highway safety and movement of farm machinery on public roads.
- I The use of flashing amber lights is acceptable in most localities. However, some localities prohibit their use. Local laws should be checked for all lighting and marking requirements.
- I At all times, when driving the tractor and equipment on the road or highway under 20mph (32kph) use flashing amber warning lights and a slow moving vehicle (SMV) identification emblem. Do not exceed 20 mph (32 kph). Reduce speed on rough roads and surfaces.
- I Plan your route to avoid heavy traffic.
- I Always install transport locks, pins or brackets before transporting.
- I Do not drink and drive.
- I Be a safe and courteous driver. Always yield to oncoming traffic in all situations, including narrow bridges, intersections, etc. Watch for traffic when operating near or crossing roadways.
- I Turn curves or go up or down hills only at a low speed and at a gradual steering angle. Make certain that a least 20% of the tractor’s weight is on the front wheels to maintain safe steering. Slow down on rough or uneven surface. Always check tractor manual for proper use on slopes.
- I Be careful when turning sharp corners.
- I Never allow riders on either tractor or post hole digger.

STORAGE SAFETY



- I Following operation, or when unhooking the post hole digger, stop the tractor, set the brakes, disengage the PTO, shut off the engine and remove the ignition keys.
- I Store the unit in an area away from human activity.
- I Do not park equipment where it can be exposed to direct contact to livestock for long periods of time. Damage and livestock injury could result.
- I Make sure all parked machines are on a hard, level surface and engage all safety devices.

SAFETY SIGNS

⚠ DANGER		
	<p>Rotating Parts Hazard Keep Away</p> <p><i>To Prevent Serious Injury or Death from Rotating Parts:</i></p> <p><i>Si no entiende ingles, se prefiere que busque a alguien que interprete las instrucciones para usted.</i></p> <ul style="list-style-type: none">• Read and understand owner's manual before operating.• Do not operate without all shields and guards in place.• Do not use body weight to force the auger into the ground or to locate auger point when auger is turning.• Keep away from auger, cutting head and driveline when engine is running.	

1

⚠ WARNING
SAFETY GUARD - DO NOT REMOVE

2

⚠ DANGER
GUARD MISSING
DO NOT OPERATE - PUT GUARD ON

3

⚠ DANGER
<p>TO PREVENT SERIOUS INJURY OR DEATH:</p> <ul style="list-style-type: none">• Contact dealer, make sure your machine has all current safety guards and shields in place.• Do not operate without all guards and shields in place.• Do not operate when auger is higher than 12 inches above ground level. Doing so may cause driveline to bind, resulting in equipment damage or operator injury.• Stop auger rotation before maneuvering, relocating or transporting.• Do not use PTO adaptors.

4



MODEL NO.
DESCRIPTION
SN# XXXXXXXXXX

5

⚠ WARNING

**DO NOT EXCEED PTO
SPEED OF
540 RPM**

Direction of Rotation



**Tractor PTO master
shield, PTO drive
shaft guarding and
PIC guards are to be
kept in place. Do not
remove guards.**

6

⚠ DANGER

**DO NOT ATTACH THIS IMPLEMENT OR ATTEMPT TO OPERATE
UNTIL YOU HAVE READ AND UNDERSTOOD ALL INSTRUCTIONS
IN THE OWNER'S MANUAL. IF AN OWNER'S MANUAL IS NOT
AVAILABLE, CONTACT: KING KUTTER, INC. WINFIELD, AL 35594
(205) 487-3202 OR WWW.KINGKUTTER.COM.**

7

WARNING

- This digger may not be compatible with all tractor models.
- Before operating, mount the boom and A-frame to the tractor.
- Raise up and lower the 3-point lift arms to the max and min positions.
- Check that there is no tractor/boom interference at any position.
- If there is not Interference, continue with the assembly of the digger.
- Failure to do so may result in damage to the tractor, digger, and/or personal injury.

8

DANGER

Never use a Shear bolt with different grade than specified or with more than 1/8" protruding from the nut. Keep spare Shear bolts on hand. See Owner's Manual for bolt specifications and recommendations.

9

DANGER



**GUARD MISSING.
DO NOT OPERATE.**

DANGER



**GUARD MISSING.
DO NOT OPERATE.**

DANGER

10

⚠ DANGER



**ROTATING DRIVELINE
CONTACT CAN CAUSE DEATH**

KEEP AWAY!

DO NOT OPERATE WITHOUT -

- All driveline guards, tractor and equipment shields in place.
- Drivelines securely attached at both ends.
- Driveline guards that turn freely on driveline.

11

⚠ WARNING

**REMOVE LEGS
BEFORE USE**

13

⚠ WARNING

This product can expose you to chemicals including Cumene, which is known to the State of California to cause cancer.

For more information go to www.P65Warnings.ca.gov.

14

⚠ DANGER

TO PREVENT SERIOUS INJURY OR DEATH:

Si no entiende ingles, se prefiere que busque a alguien que interprete las instrucciones para usted.

- Read and understand owner's manual before operating.
- Operate only from the tractor seat.
- Stay away from rotating parts. Keep others away.
- Do not dig around underground utility lines without checking with authorities.

12

**Operators Manuals & Parts
are available from
your dealer, or**

Taylor Pittsburgh Mfg. Inc.

PO Box 1200

Winfield, AL 35594

(205) 487-3202

or

www.taylorpittsburgh.com

15



 DANGER
SHIELD MISSING DO NOT OPERATE - PUT SHIELD ON

16



Know what's below.
Call before you dig.

17

 DANGER		
GUARD MISSING <i>When this is visible</i> DO NOT OPERATE		KEEP CLEAR! <i>Keep Others Away!</i> ENTANGLEMENT HAZARD <i>can cause Serious Injury or Death</i>
<ul style="list-style-type: none"> ● Never manually position the auger or manually force the auger into the ground. ● This machine is designed to be operated only from the tractor seat. ● Keep everyone clear of all moving parts of the digger while in operation. 		

18

THIS DECAL IS ON AUGER

SAFETY SIGNS LOCATIONS

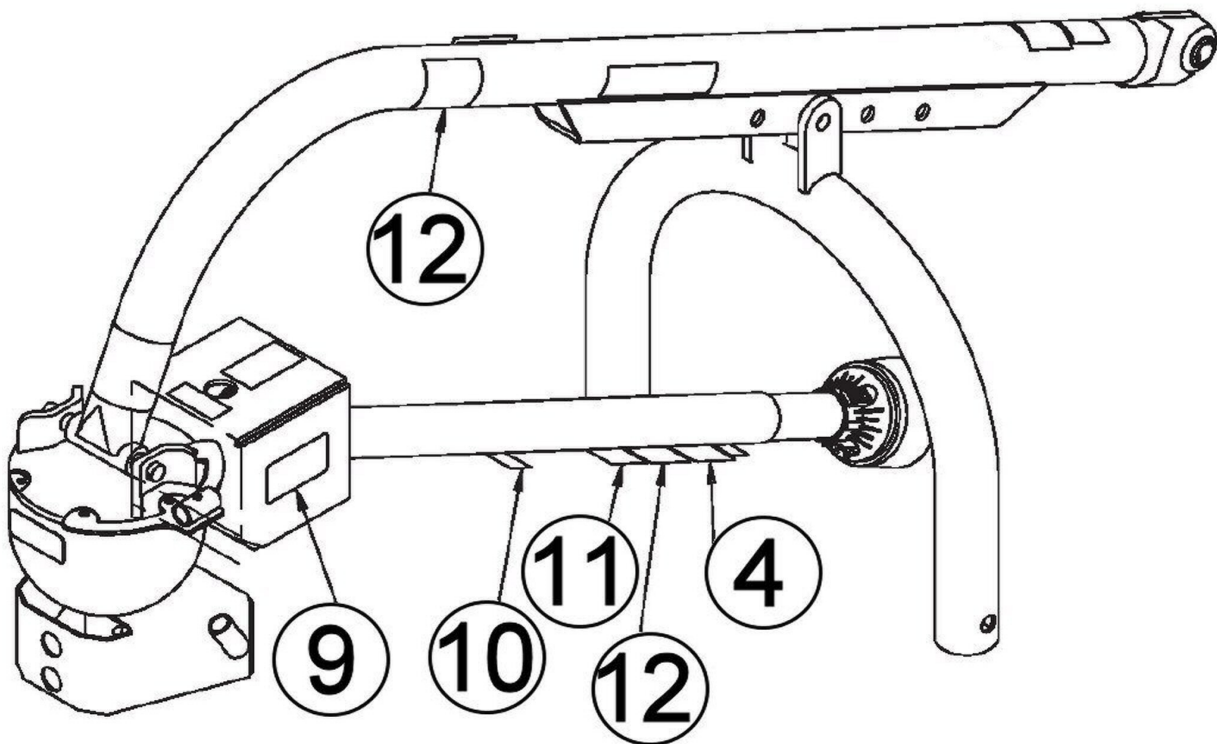
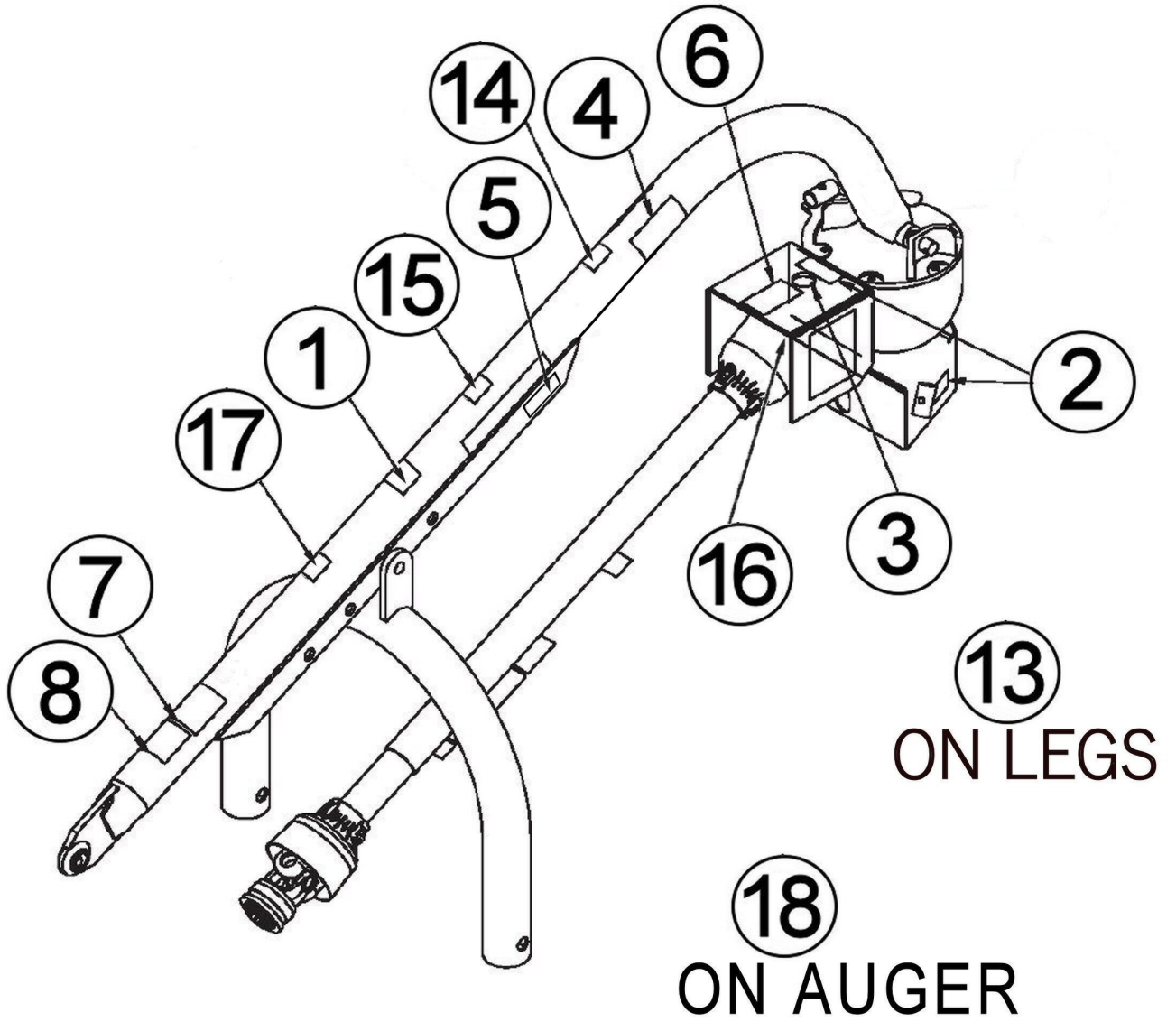

ASSEMBLY & ATTACHING TO TRACTOR

SET-UP INSTRUCTIONS

The digger is shipped partially assembled. Assembly will be easier if the components are aligned and loosely assembled before tightening hardware. Recommended torque values for hardware are located on page 24.

Select a suitable working area. Uncrate parts boxes and layout parts and hardware to make location easy. Refer to illustrations, accompanying text, parts list and exploded view drawings.

IMPORTANT

- **Post hole digger gearboxes are shipped without lubrication. Gearboxes must be serviced with 90W gear lube before operation.**

ATTACH A-FRAME AND BOOM TO TRACTOR

A tractor is required during assembly of post hole digger. A tractor will make part fit-up, part alignment, and part handling easier.

1. Connect lift arm pins (6), Figure 6, and hardware supplied with pins to the A-frame assembly (2). Mount PTO shaft storage bracket as shown on outside of A-Frame.

NOTE: On tractors with 3-point arm spacing of 32 inches, place mounting pins on the outside of the yoke assembly. On tractors with 3-point arm spacing of 26 inches or less, place mounting pins on the inside of the yoke assembly.

2. Connect A-frame assembly to the tractor 3-point arms.
3. Attach boom (1) to the tractor top link bracket.
4. Align A-frame assembly with the adjustment channel on the boom, starting with the second hole. Secure into position using boom adjustment pin (3) and lynch pin (5).

IMPORTANT

• **With boom attached to tractor, raise boom by hand. Check clearance between boom and top link bracket. If interference exists, change hole location and recheck. Failure to check can result in damage to the tractor or boom.**

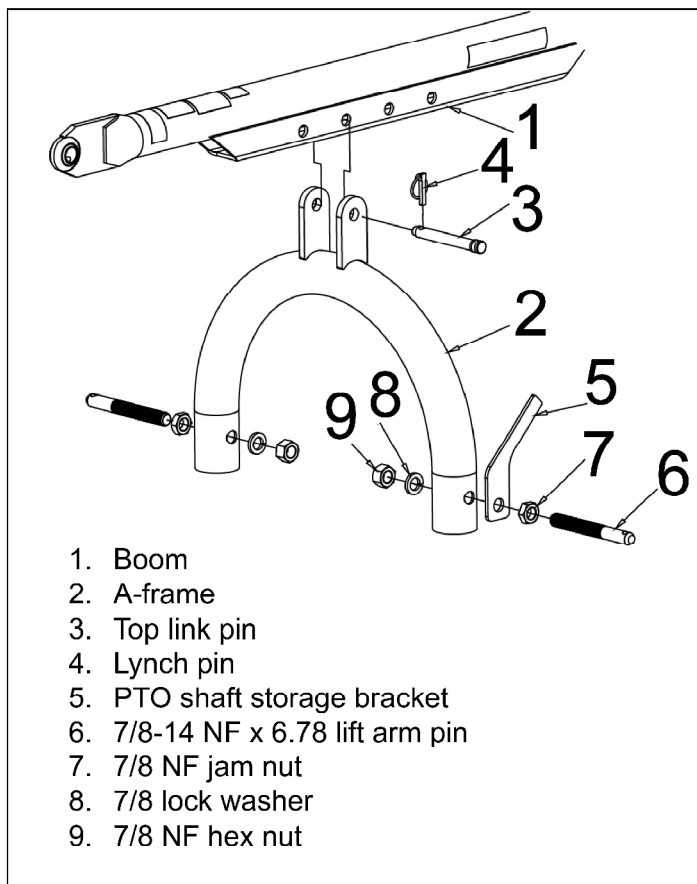

Figure 6. A-Frame to Boom Assembly

ATTACH GEARBOX TO BOOM

See Figure 7

1. Place gearbox on level section of ground resting on output shaft guard.
2. Lower boom and align gearbox mount holes with boom mount hole.
3. Secure gearbox to boom using the supplied pin (4) and cotter pins(3).

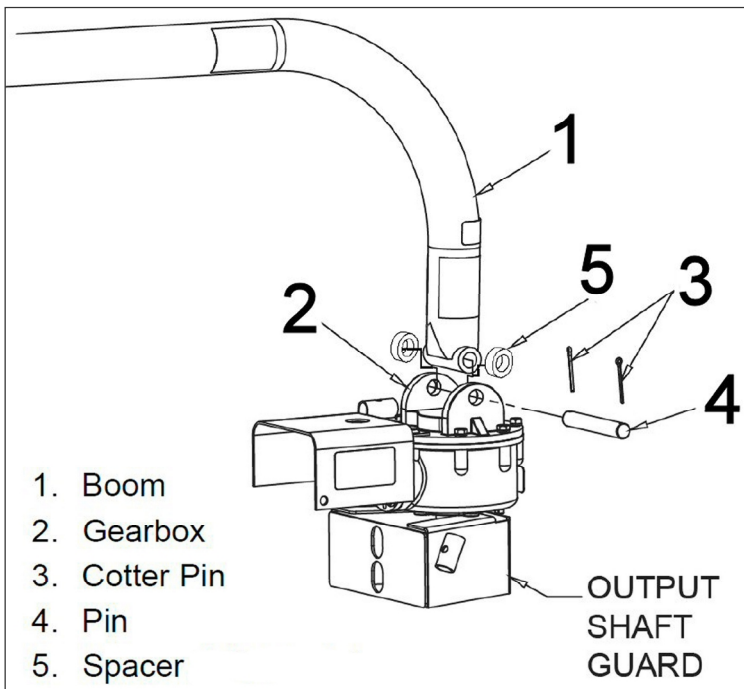

Figure 7. Gearbox to Boom Installation

INSTALL DRIVELINE

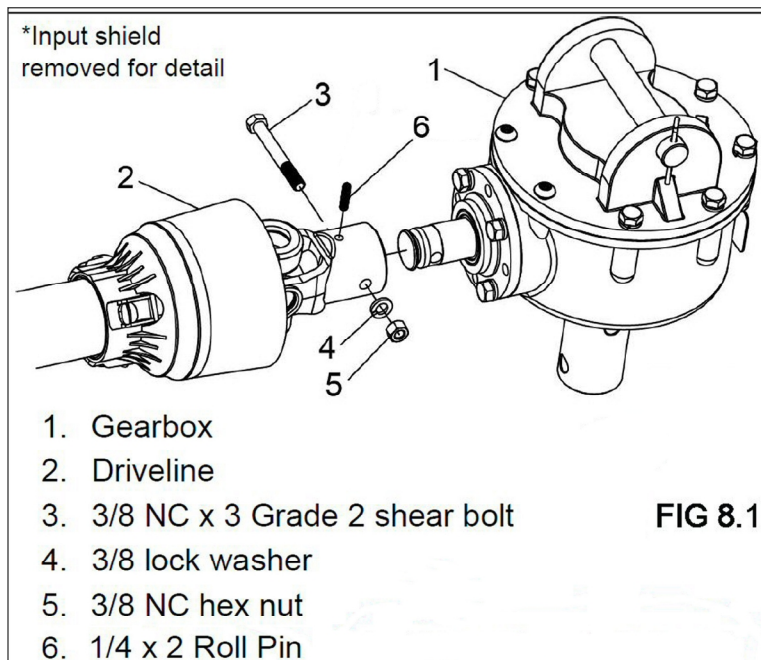

Figure 8.1 Driveline Installation

1. Clean input shaft on gearbox and smooth bore of driveline yoke. Remove any foreign material or paint. Lightly file any nicks or dents.
2. Grease the input shaft of the gearbox. This reduces the chance of the driveline galling the shaft if the shear bolt should fail.
3. Slide driveline over input shaft and align cross holes. Insert shear bolt(3) to hold parts together.
4. Install the roll pin (6) into driveline yoke to secure driveline to gearbox shaft. Remove shear bolt (3) from cross hole. Driveline yoke should spin freely on shaft.
5. Secure drive line to input shaft with shear bolt (3), lock washer (4), and hex nut (5).

IMPORTANT: The set screw or roll pin prevents the driveline from coming off gearbox shaft if the shear bolt should shear.

SIZING PTO SHAFT

CHECK DRIVELINE FOR MINIMUM OVERLAP

(SEE FIGURE top of next page)

With PTO shaft hooked to tractor & post hole digger raise and lower digger to find PTO's longest extended point and at that point measure length of cover of the PTO at **(A)**, transfer the measurement of **(A)** to **(B)**, mark cover at the end of measurement of **(B)**, then make sure measurement of **(C)** is at least 6".

SIZING PTO SHAFT....continued

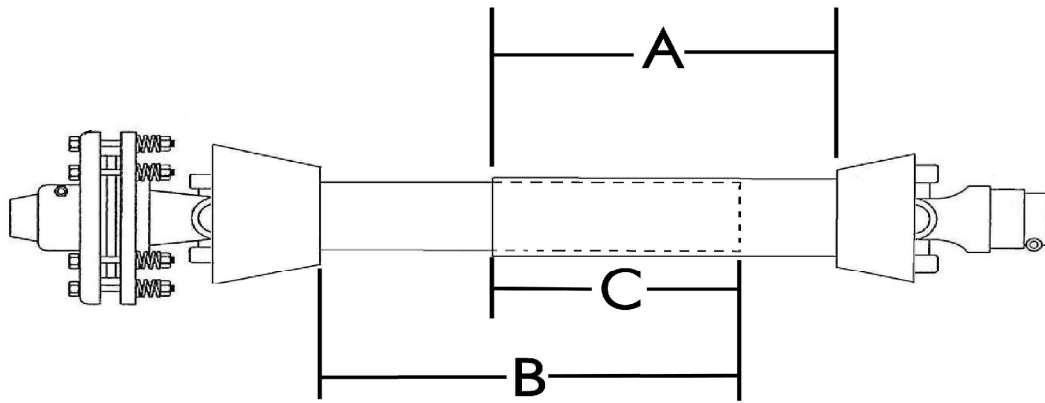

STEP 1

Cutting the PTO shaft to length. **NOTE:** Be sure to cut equal lengths of each PTO shaft section. Clamp end of PTO shaft in a vice and cut off shield where marked. **(Figure 1-A & 1-B)**



Figure 1-A

STEP 2

Using cut section of the shield as a guide cut shaft off the same amount. (Figure 2)

STEP 3

Repeat steps 1 and 2 for other PTO shaft section.

STEP 4

Use a file to deburr PTO shafts. Clean up all chips, burrs and filings from both ends of the PTO shaft.



Figure 1-B



Figure 2

AUGER ATTACH TO GEARBOX

Never exceed the recommended auger capacity of the post hole digger. Use of an incorrect auger or auger extension can cause equipment damage, loss of operator control and personal injury. See specifications on page 4 for available auger capacities.

1. Raise boom (1), allowing enough space to install auger.
2. Slide auger over gearbox output shaft and install 1/2 bolt (3), 1/2 lock washer (4), and 1/2 nut (5) in both hole locations. Tighten all hardware.

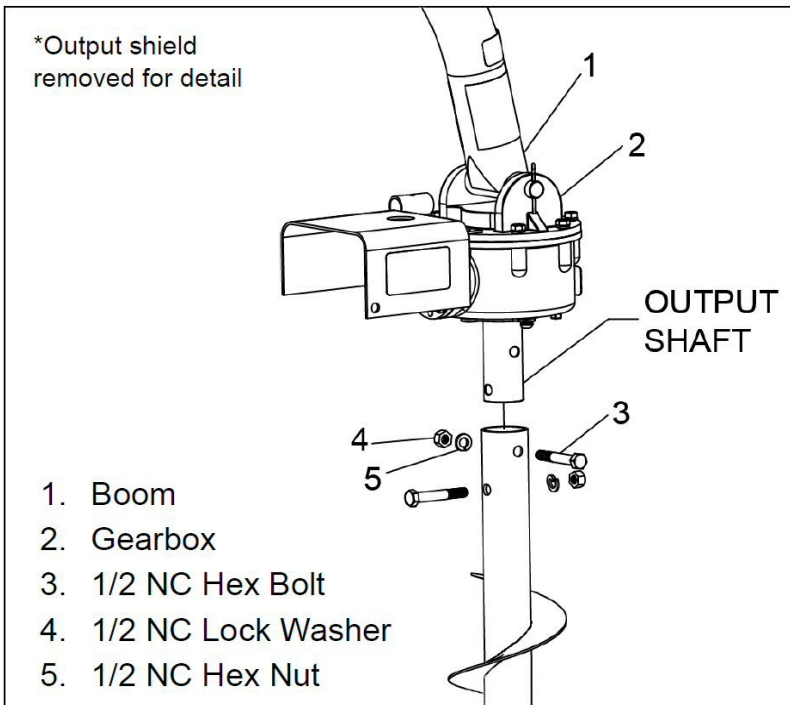

Figure 12. Auger to Gearbox Installation

FILL GEARBOX

IMPORTANT: Post hole digger gearbox is shipped without lubrication. Gearbox must be filled with SAE 90W gear lube before operation.

1. Level gearbox and remove top fill plug and top sight plug on back side of gearbox.
2. Fill gearbox with SAE 90W gear lube until oil runs out of sight hole.
3. Install both plugs.

INSTALL HANDLE

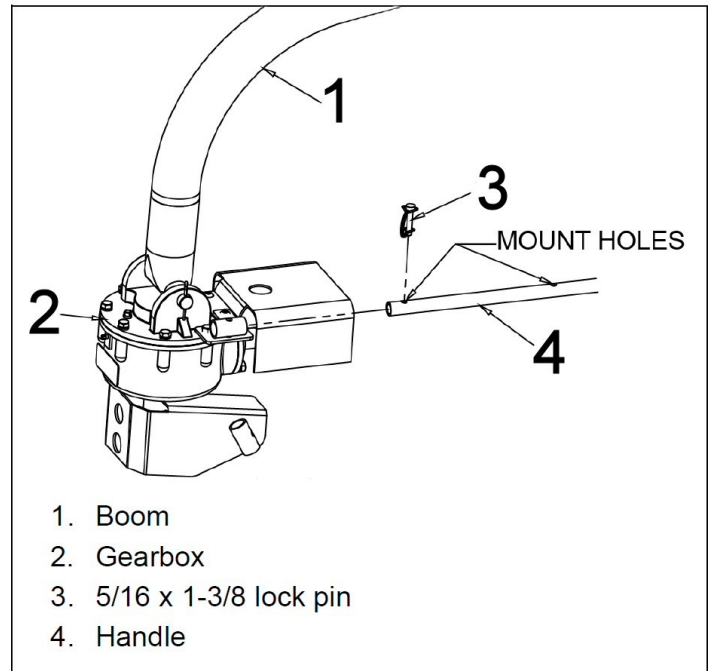

Figure 13. Handle Installed

1. The handle (4) has three holes that can be pinned at the gearbox: one on the short end and two on the long end. Use the hole that allows for safe clearance and access to the handle from the tractor seat.
2. Install supplied handle grip once the handle position has been determined.



OPERATING INSTRUCTIONS

- Keep bystanders 25 feet away from equipment working area.
- Do not use body weight or any body part to force the auger into the ground or to position auger when auger is turning.
- Never aim auger point with hands on auger, gearbox, boom or driveline. To place auger point use 3-point arms and handle.
- Do not shovel dirt away from a running auger. The shovel could be caught and thrown by auger.

OPERATION

The post hole digger is intended to dig holes in soil free from rocks, tree roots, and other obstructions. It is designed to be mounted on an tractor 3-point hitch and powered by a 540 rpm, 6 spline PTO.

The post hole digger and its individual components are Not to be used for anything other than their intended use. The operator is responsible for the safe operation of the equipment. The operator must be properly trained and should be familiar with the equipment, tractor and all safety practices before starting operations.

Post hole diggers are designed for one-man operation. You must always be in the tractor seat while digging holes. **It is the responsibility of the operator to see that no one else is within 25 feet of the digger when it is operating.** Accidents have occurred when more than one person is in the immediate area of the operating equipment.



Do not put digger into service unless all shields and guards are in place and in good condition. Replace if damaged.



Keep hands, feet, and clothing away from equipment while engine is running. Stay clear of all moving parts.

Do not use digger unless auger point and all cutting edges are intact and in good working order.



Always wear relatively tight and belted clothing to avoid getting caught in moving parts. Wear sturdy, rough soled work shoes and protective equipment for eyes, hair hands, hearing and head.

Tighten all bolts, nuts and screws to torque specifications. Check that all cotter pins are installed securely to ensure equipment is in a safe condition before putting unit into service.



- **Consult local utilities before digging. Know location of all underground cables, pipelines, overhead wires and other hazards in working area and avoid contact.**

Thoroughly read and understand your Operator's Manual.

Before starting operation, clear area of objects that could wrap around the auger or might be thrown. Contact local utility company to make sure there are no buried gas lines, electrical cables, etc. in the work area.

Check for ditches, stumps, holes and other obstacles that could cause the tractor to roll. To dig properly, your digger must be able to raise and lower through the highest and lowest points of your lift arm travel without binding against the tractor frame. Check carefully before attaching the auger, that it does not bind, adjust the tractor 3-point linkage so that all parts move freely. Use stabilizer bars, adjustable sway chains or sway blocks on your tractor lift arms to keep the post hole digger from swaying side to side. Adjust as tight as practical for best performance. Remove or place tractor drawbar in safe position.



Post hole digger gearboxes are shipped without lubrication. Gearboxes must be serviced with 90W gear oil before operation. If PTO driveline interferes with swaying drawbar, swing drawbar out of the way or remove.

PRE-OPERATION CHECKLIST

- Review and follow all safety rules and safety decals instructions.
- Check that all safety decals are installed and in good condition. Replace if damaged.
- Check that all shields and guards are properly installed and in good condition. Replace if damaged.
- Consult local utilities before digging. Know location and avoid contacting underground cables, pipelines, overhead wires and other hazards in working area.
- Check the auger point and all cutting edges are intact and in good repair.
- Check that equipment is properly and securely attached to the tractor.
- Make sure driveline locking pin slides freely and is seated firmly in tractor PTO spline groove or gearbox PTO spline groove.
- Lubricate all grease fitting locations. Make sure telescoping PTO shafts and universal joints are lubricated.

- Make sure tractor 3-point lift does not interfere with hydraulic hoses or driveline through full turning range.
- Check that all hardware and cotter pins are properly installed and secure.
- Check altitude adjustment of auger.
- Check and keep all bystanders 25 feet away from working equipment area.
- Before starting tractor engine operator must be in tractor seat with seatbelt fastened. Place transmission in neutral or park, engage brake and disengage tractor PTO.



CAUTION



- Always sit in the tractor's seat when digging holes.
1. Position the tractor so that the auger point is placed where the hole is to be dug. The point of the auger should be approximately 3" back of center of the gearbox. As the auger works into the ground, this slight angle will straighten due to the pivoting action of the boom movement downward. If the auger has slight tilt, turn off tractor and correct by adjusting lift arm on the tractor hitch.
 2. Set tractor brakes, shift tractor into park or neutral before engaging PTO and digging. Always sit in the tractor's seat when digging holes.
 3. Lower auger point slowly to the ground with PTO disengaged. The positioning handle is used to position the auger as it is lowered to the ground. The handle should be easily accessible when sitting in the tractor seat and operating the tractor 3-point lift arms. Adjust as necessary. With the auger point lowered to the ground, set the engine speed to idle, the engage the PTO. Set tractor PTO speed to 540 rpm. Under no circumstances should the PTO run more than 540 rpm. If the auger tilts too far forward or to the rear, it may be necessary to move the tractor slightly. Be careful not to bend the auger.
 4. As the auger penetrates the ground, lower the unit slowly with the 3-point lift arms. Do not let the auger screw itself into the ground. Auger must dig with the dirt broken up and carried to the top by the auger flighting.
 5. Dig the hole in small steps. Dig down several inches, then bring the auger up to let the soil clear. Repeat until the desired depth is reached. This allows better control of the auger and can prevent difficulties that could lead to an accident.

IMPORTANT

- **Be careful when raising the auger as high as your tractor's 3-point lift arms will go. This can put the PTO shaft universal joints at an extreme angle and can cause damage to the PTO shaft. It is best to raise the auger just enough to clear the hole when PTO is engaged.**
- **It is recommended not to raise the auger more than (6) six inches above the ground while it is running. Once the hole is dug to the desired depth, raise the auger while rotating to bring the dirt out of the hole.**

To get a clean hole, it is sometimes it is best to lower the auger into the hole with the auger turning then, when at the bottom, top the rotation and raise the auger while not turning. This brings the dirt up with little left in the hole. Disengage the PTO when traveling between holes.

In some types of soil it may be necessary to use the 3-point lift arms to prevent the auger from screwing itself into the ground.

When the ground is too tough to penetrate with your cutting edges and point, sharpen or replace them sand try again. These are replaceable parts and must be in good condition to penetrate.

LODGED AUGER



WARNING



- **When dislodging a stuck auger, disengage PTO, stop engine, set parking brake, remove key and disconnect PTO from tractor. Remove and store wrench before starting engine.**
 - **Removing a lodged auger can be dangerous work. Be careful.**
 - **Do not attempt to raise the auger while turning it with a wrench, or with a wrench attached to the auger. Injury may occur if the PTO is engaged or the 3-point lift arms suddenly raise the auger.**
1. If the auger gets stuck in wet clay, stones or roots, disengage the PTO immediately and turn off the engine.
 2. With tractor engine off and key removed, disconnect the PTO shaft from the tractor.
 3. Turn the auger backwards with a large pipe wrench until auger is free and completely out of the obstruction.

4. Remove and store wrench all other tools used during this process.
5. Repeat steps in operating to continue digging holes.

SHEAR BOLT REPLACEMENT



WARNING



- **Never replace shear bolt or auger retaining bolt with a different length or grade. Always use a SAE grade 2 bolt as a replacement.**

Shear bolts are important for both safety and preventing damage to the digger. Their intended function is to break when too much force is applied.

Always replace shear bolts at the gearbox input with the manufacturer's part or one of the same size, length and **SAE Grade 2** specification. Hardened nut or bolts that are too long can cause accidents resulting in injury or death. The roll pin (Figure 3) prevents the driveline from coming off gearbox shaft if the shear bolt should shear.

*Input shield removed for detail

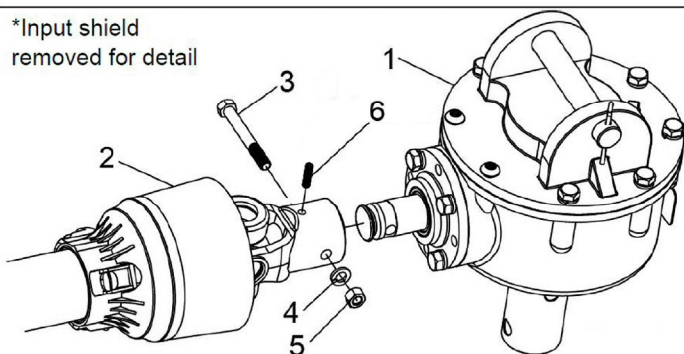

1. Gearbox
2. Driveline
3. 3/8 NC x 3 Grade 2 shear bolt
4. 3/8 lock washer
5. 3/8 NC hex nut
6. 1/4 x 2 Roll Pin

Figure 3. Shear Bolt Replacement

TRANSPORT



WARNING



- **Do not operate PTO during transport.**
- **Not intended to operate or travel on public roadways.**
- **Keep bystanders 25 feet away from equipment during transport.**
- **Do not transport with parking stands installed or in storage position.**

- The post hole digger auger is free-swinging, and care should be taken while transporting the digger. Be sure auger is completely retracted from the hole before attempting to move the tractor.
- **DO NOT** transport the post hole digger while the PTO is engaged as this could cause the universal joints of the PTO shaft into a sharp operating angle and cause the PTO to fail.
- Pay particular close attention to the Safety messages regarding transport. Avoid unnecessary injuries and equipment damage by exercising caution and be conscience of travel procedures.
- Attaching the implement to the tractor increases the overall length of the working unit. Allow additional clearance for the implement to swing during turning.
- Raise the digger as high as possible for transport.

STORAGE

1. Drain and change the oil in your gearbox.
2. Check and replace, where necessary, blades, bolts, nuts on the digger.
3. Clean digger and touch up any rust spots.
4. Replace any safety decals if damaged, illegible, or painted over.
5. Make sure PTO driveline yoke and gearbox input shaft are clean and free of burrs. Keep well lubricated to prevent galling of yoke and input shaft when shear bolt shears.
6. Keep all shields in place. Replace with new shields if damaged or missing.
7. Keep cutting edges sharp. Sharp cutting edges dig easier and better. Outer cutting edges on large augers wear faster than inner cutting edges; switching teeth will even wear.
8. Store implement in clean and dry location.

REMOVE DIGGER FROM TRACTOR

When off the tractor, post hole diggers can be an awkward piece of equipment to handle. Be careful not to pinch fingers and hands in the various hinge points of the digger.

PARKING STAND INSTALLATION

FIG. 4 below

1. Raise the digger as high as possible.
2. Insert the two parking stand legs (4) into the lug (2) on the front of the gearbox output shield. Secure with two locking pins (3).
3. Lower digger until two legs and the auger form a tripod. This will support the post hole digger in a vertical position.
4. Remove 3-point arms and driveline from the tractor.
5. Hang the PTO end of the driveline (5) over the PTO shaft storage bracket (6) to help prevent dirt and debris from accumulating in the locking collar on the driveline PTO yoke.

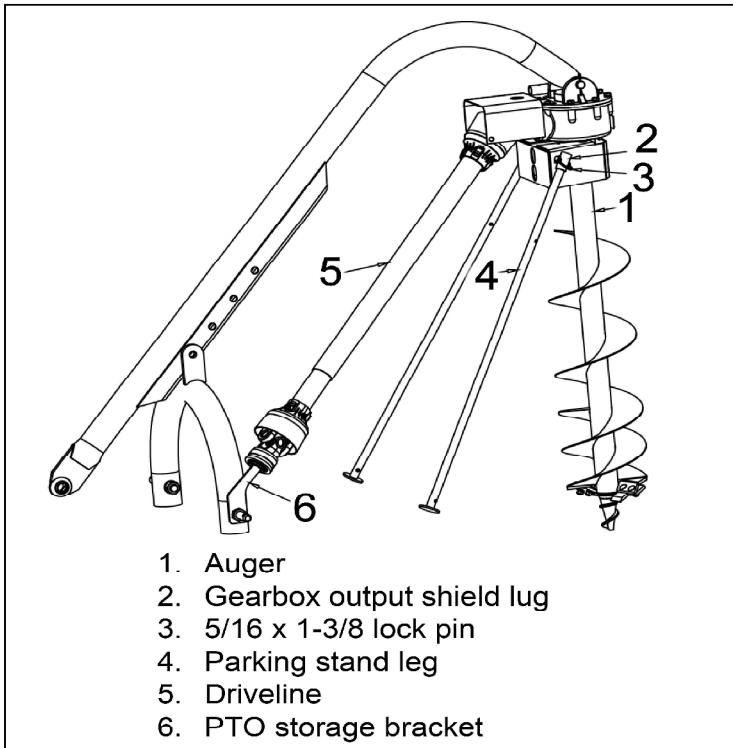
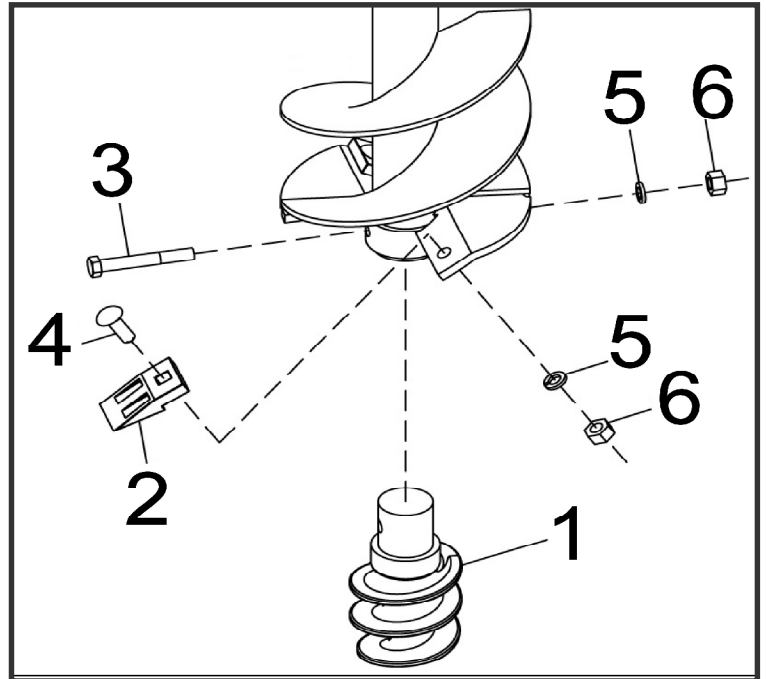

Figure 4. Parking Stand Installation

REPLACE CUTTING EDGE

Cutting edges and center points are replaceable. They should be sharpened or replaced when worn.

1. Remove carriage bolt (4), lock washer (5), and hex nut (6) holding cutting tooth to the auger.
2. Replace or sharpen cutting tooth. Cutting tooth can be sharpened using a steel file or grinder. Restore the cutting edge to an approximate 10 degree angle on both top and bottom side of tooth. Discard old cutting tooth and replace with new tooth when sharpening has ground the cutting edge into the recessed pockets on top of the cutting tooth.
3. Remove center point (1) by removing cap screw (3), lock washer (5), and hex nut (6).



AFTER EACH USE

- Remove large debris such as clumps of dirt, grass, crop residue, etc. from digger.
- Inspect digger and replace worn or damaged parts.
- Replace any safety decals that are missing or not readable.

PERIODICALLY or BEFORE EXTENDED STORAGE

- Clean large debris such as clumps of dirt, grass, crop residue, etc. from digger.
 - Remove the remainder using a low pressure water spray.
1. Be careful when spraying near scratched or torn safety decals or near edges of decals as water spray can peel decal off.
 2. Be careful when spraying near chipped or scratched paint as water can lift paint.
 3. If a pressure washer is used, follow the advice of the pressure washer manufacturer.
- Inspect digger and replace worn or damaged parts.
 - Sand down scratches and the edges of areas of missing paint and coat with spray paint of matching color.
 - Replace any safety decals that are missing or not readable. See Safety Decals section for location drawing.

233-PHD Parts Diagram

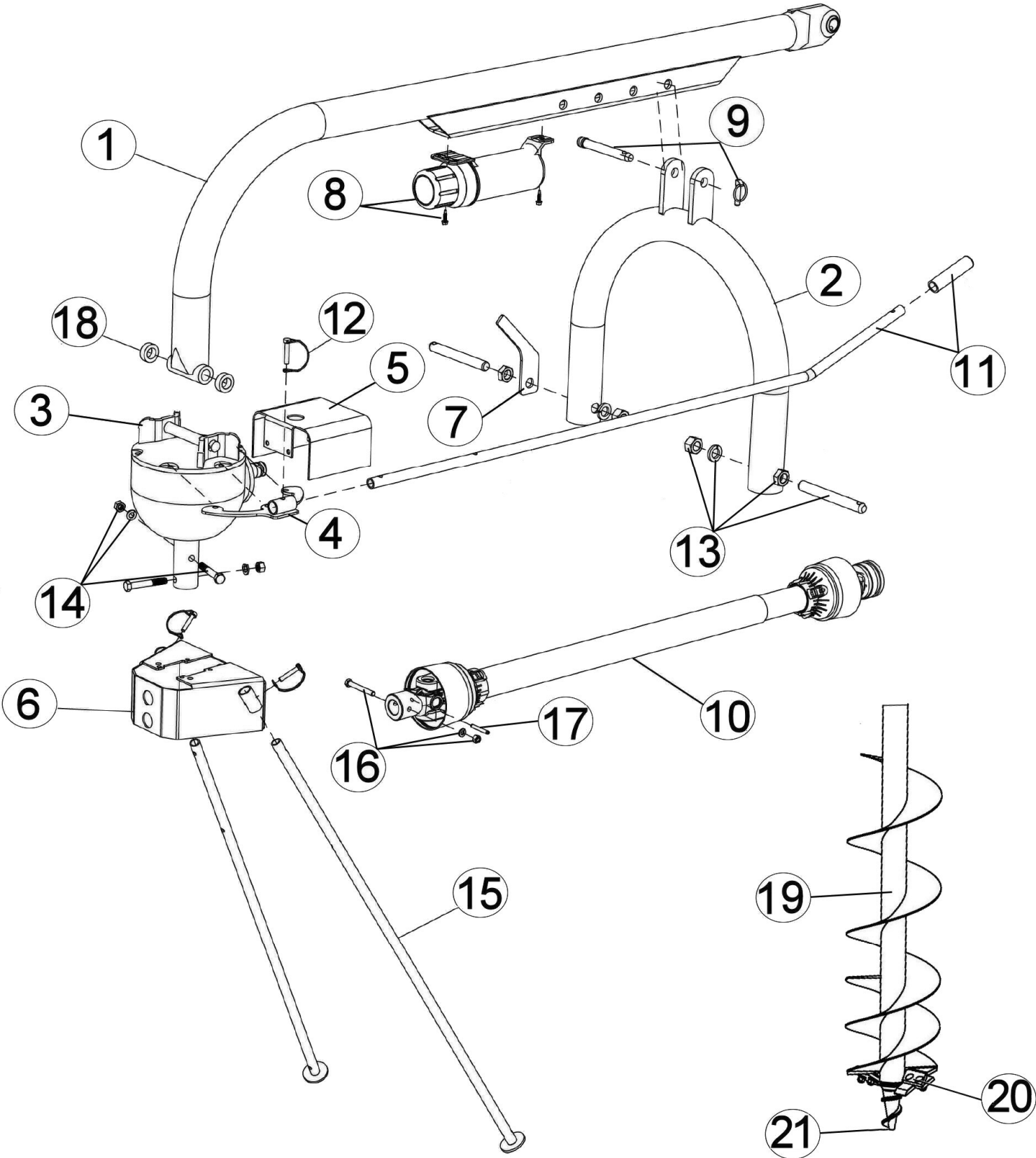

233-PHD PARTS

Ref. No.	Part Name	Part #
1	PHD BOOM	90050000
2	PHD A-FRAME	90050500
3	PHD GEAR BOX	90051000
4	PHD LUG BRACKET	90051500
5	PHD INPUT GUARD	90052000
6	PHD OUTPUT GUARD	90052500
7	PHD PTO STORAGE BRACKET	90053000
8	PHD MANUAL CANISTER W/SCREWS	58050000
9	PHD TOP LINK PIN (3/4" PIN & 7/16" LYNCH PIN)	58050500
10	PHD PTO SHAFT	90055000
11	HANDLE W/GRIP	58051000
12	PHD LOCK PIN, 5/16" X 1-3/8"	90056500
13	PHD LIFT PINS	58051500
14	PHD AUGER MOUNTING BOLTS	58052000
15	PHD LEG KIT W/DECAL	58052500
16	PHD SHEAR BOLT 3/8" X 3" GR2	58053000
17	PHD ROLL PIN 1/4" X 2"	58053500
18	PHD SPACER	58054000
19	POST HOLE DIGGER AUGER 6" (Sold separately)	233-AUG-06-ZX
19	POST HOLE DIGGER AUGER 9" (Sold separately)	233-AUG-09-ZX
19	POST HOLE DIGGER AUGER 12" (Sold separately)	233-AUG-12-ZX
20	6" & 9" TEETH & BOLT PKG.	58055500
20	12" TEETH & BOLT PKG.	58056000
21	AUGER POINT & BOLT PKG.	58056500

BOLT TORQUE CHART

Always tighten hardware to these values unless a different torque value or tightening procedure is listed for a specific application.

Fasteners must always be replaced with the same grade as specified in the manual parts list.

Always use the proper tool for tightening hardware: SAE for SAE hardware and Metric for metric hardware.

Make sure fastener threads are clean and you start thread engagement properly.

All torque values are given to specifications used on hardware defined by SAE J1701 MAR 99 & J1701M JUL 96.

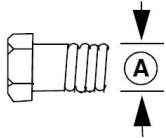

SAE SERIES TORQUE CHART

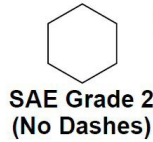

Ⓐ Diameter (Inches)	Wrench Size	MARKING ON HEAD					
		SAE 2		SAE 5		SAE 8	
		lbs-ft	N-m	lbs-ft	N-m	lbs-ft	N-m
1/4"	7/16"	6	8	10	13	14	18
5/16"	1/2"	12	17	19	26	27	37
3/8"	9/16"	23	31	35	47	49	67
7/16"	5/8"	36	48	55	75	78	106
1/2"	3/4"	55	75	85	115	120	163
9/16"	13/16"	78	106	121	164	171	232
5/8"	15/16"	110	149	170	230	240	325
3/4"	1-1/8"	192	261	297	403	420	569
7/8"	1-5/16"	306	416	474	642	669	907
1"	1-1/2"	467	634	722	979	1020	1383

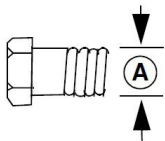

METRIC SERIES TORQUE CHART

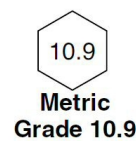
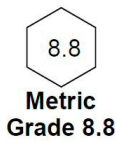

Ⓐ Diameter & Thread Pitch (Millimeters)	Wrench Size	COARSE THREAD				FINE THREAD				Ⓐ Diameter & Thread Pitch (Millimeters)
		MARKING ON HEAD				MARKING ON HEAD				
		Metric 8.8		Metric 10.9		Metric 8.8		Metric 10.9		
		N-m	lbs-ft	N-m	lbs-ft	N-m	lbs-ft	N-m	lbs-ft	
6 x 1.0	10 mm	8	6	11	8	8	6	11	8	6 x 1.0
8 x 1.25	13 mm	20	15	27	20	21	16	29	22	8 x 1.0
10 x 1.5	16 mm	39	29	54	40	41	30	57	42	10 x 1.25
12 x 1.75	18 mm	68	50	94	70	75	55	103	76	12 x 1.25
14 x 2.0	21 mm	109	80	151	111	118	87	163	120	14 x 1.5
16 x 2.0	24 mm	169	125	234	173	181	133	250	184	16 x 1.5
18 x 2.5	27 mm	234	172	323	239	263	194	363	268	18 x 1.5
20 x 2.5	30 mm	330	244	457	337	367	270	507	374	20 x 1.5
22 x 2.5	34 mm	451	332	623	460	495	365	684	505	22 x 1.5
24 x 3.0	36 mm	571	421	790	583	623	459	861	635	24 x 2.0
30 x 3.0	46 mm	1175	867	1626	1199	1258	928	1740	1283	30 x 2.0

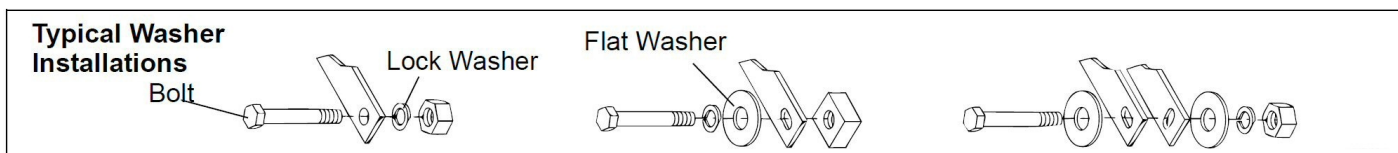

BOLT SIZE CHART

NOTE: Chart shows bolt thread sizes and corresponding head (wrench) sizes for standard SAE and metric bolts.

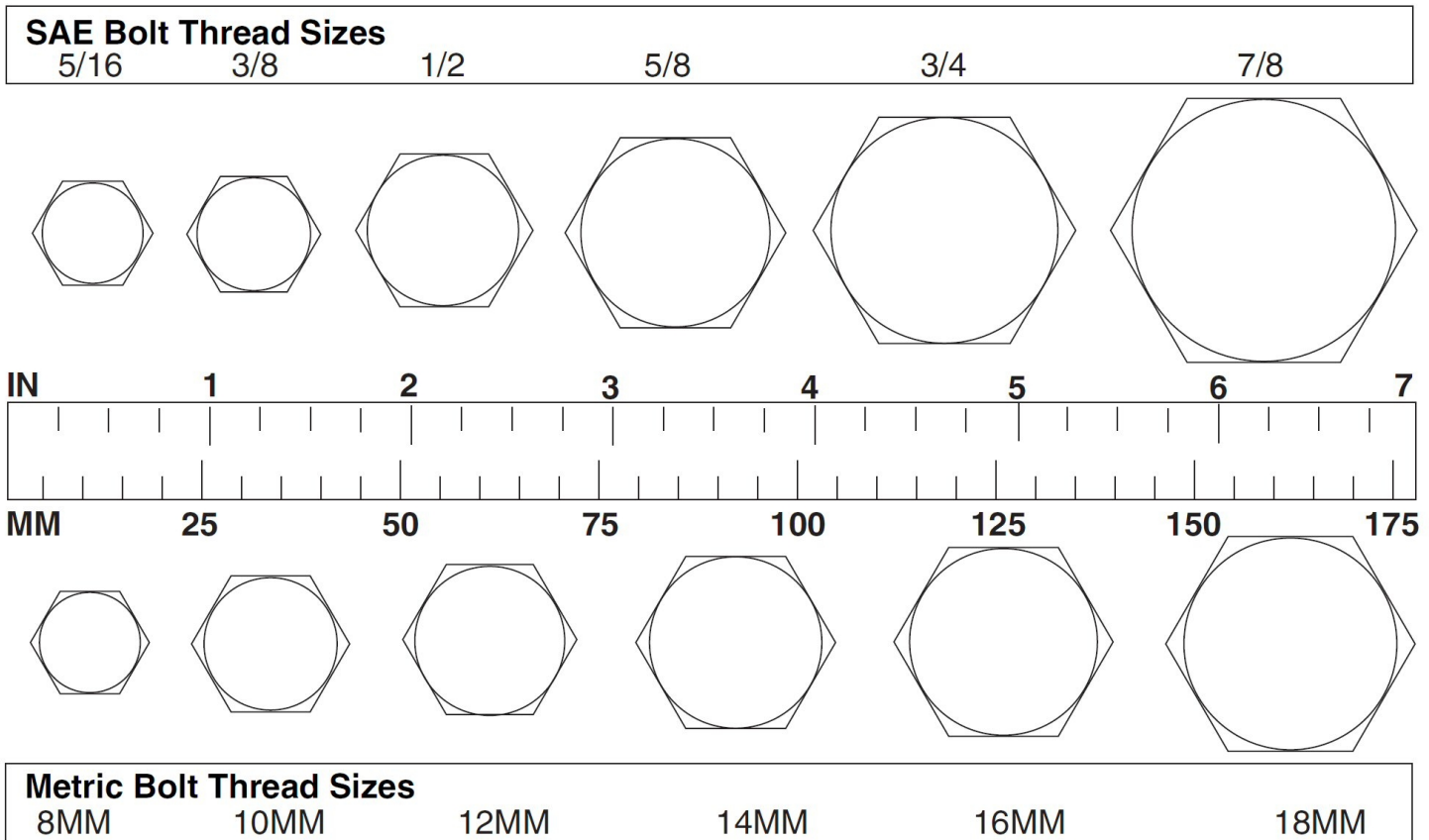

ABBREVIATIONS

AG Agriculture
 ATF Automatic Transmission Fluid
 BSPP British Standard Pipe Parallel
 BSPTM British Standard Pipe Tapered Male
 CV Constant Velocity
 CCW Counter-Clockwise
 CW Clockwise
 F Female
 GA Gauge
 GR (5, etc.) Grade (5, etc.)
 HHCS Hex Head Cap Screw
 HT Heat-Treated
 JIC Joint Industry Council 37° Degree Flare
 LH Left Hand
 LT Left
 m Meter
 mm Millimeter
 M Male
 MPa Mega Pascal
 N Newton

NC National Coarse
 NF National Fine
 NPSM National Pipe Straight Mechanical
 NPT National Pipe Tapered
 NPT SWF National Pipe Tapered Swivel Female
 ORBM O-Ring Boss - Male
 P Pitch
 PBY Power-Beyond
 psi Pounds per Square Inch
 PTO Power Take Off
 QD Quick Disconnect
 RH Right Hand
 ROPS Roll-Over Protective Structure
 RPM Revolutions Per Minute
 RT Right
 SAE Society of Automotive Engineers
 UNC Unified Coarse
 UNF Unified Fine
 UNS Unified Special



LIMITED WARRANTY

TAYLOR PITTSBURGH MFG., INC. the manufacturer, warrants only to the Original Purchaser that this equipment, under normal use and service, will be free from defects in material and workmanship for one (1) year from date of purchase providing this equipment is purchased for individual and not for commercial use. Warranty for commercial usage is 90 days. This warranty does not apply to any equipment which has been damaged or which has been subjected to abuse, misuse, negligence, abnormal wear and tear, alterations, tampering, or failure to follow operating instructions. This warranty does not cover any product or parts not manufactured by TAYLOR PITTSBURGH MFG., Inc.

Under this warranty, the manufacturer will repair or replace any part which the manufacturer determines has failed during the period of the warranty due to defects in material or workmanship. After approval by the manufacturer, the equipment or defective part must be returned to TAYLOR PITTSBURGH MFG., INC., Winfield, AL 35594.

Warranty coverage and performance is expressly conditioned on the return of the completed registration form to TAYLOR PITTSBURGH MFG., INC., Winfield, AL 35594.

PURCHASER'S EXCLUSIVE REMEDY FOR BREACH OF WARRANTY, OTHER DEFECT, OR CONDUCT GIVING RISE TO LIABILITY SHALL BE THE REPAIR OR REPLACEMENT OF THE PRODUCT SOLD, AND THE MANUFACTURER UNDER NO CIRCUMSTANCES SHALL BE LIABLE FOR ECONOMIC LOSS OR INCIDENTAL OR CONSEQUENTIAL DAMAGES. THE MANUFACTURER DISCLAIMS ALL IMPLIED WARRANTIES, INCLUDING THE WARRANTY OF MERCHANTABILITY AND FITNESS FOR PURPOSE.

Taylor Pittsburgh Mfg., Inc. reserves the right to make improvements and changes in specifications without notice or obligation to modify previous sold units.